

5.1A Solving Quadratic Equations by Graphing

1. What does "find the zeros of the function" mean?

To find the x -value(s) that make the function $f(x) = 0$.

2. When you are solving a quadratic equation by graphing, what do you look for on the graph?

The x -intercepts

#3 – 5: Determine whether the quadratic functions have two real roots, one real root, or no real roots. If possible, list the zeros of the function.

3.

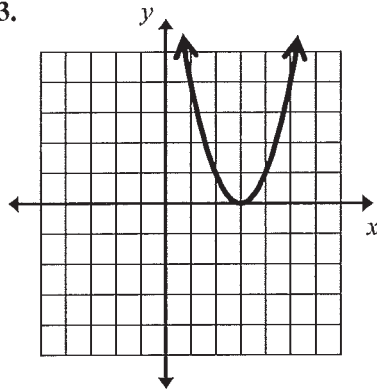

Number and type

of roots: 1 real root

Zeros: $x = 3$

4.

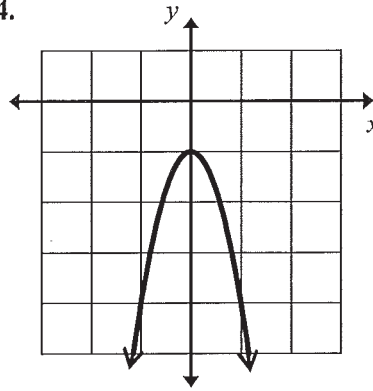

Number and type

of roots: no real roots

Zeros: none

5.

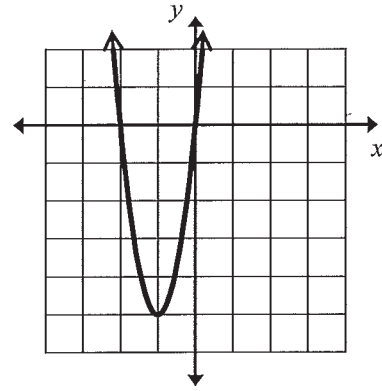

Number and type

of roots: 2 real roots

Zeros: $x = 0$ or $x = -2$

#6 – 7: Use the graph to find the zeros of the following quadratic functions. Check that the solutions work.

6. $f(x) = x^2 + 2x - 15$

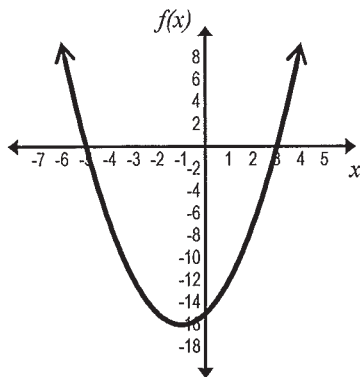

Solution(s):

$x = 3$ or $x = -5$
 $f(3) = (3)^2 + 2(3) - 15 = 9 + 6 - 15 = 0 \checkmark$
 Check: $f(-5) = (-5)^2 + 2(-5) - 15 = 25 - 10 - 15 = 0 \checkmark$

7. $f(x) = -2x^2 + 8x$

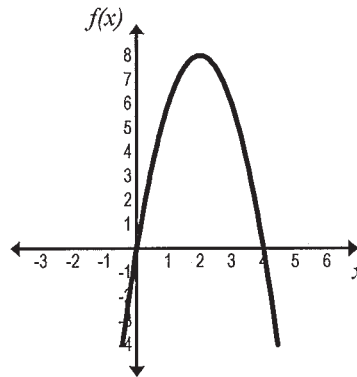

Solution(s):

$x = 0$ or $x = 4$
 $f(0) = -2(0)^2 + 8(0) = 0 + 0 = 0 \checkmark$
 Check: $f(4) = -2(4)^2 + 8(4) = -32 + 32 = 0 \checkmark$

5.1A Solving Quadratic Equations by Graphing

#8 - 9: Graph each of the following quadratic functions and use the graph to find the zeros. Create a table of values if necessary. Verify that the values truly are solutions.

8. $f(x) = -x^2 + 4x + 12$

9. $f(x) = x^2 + 3x - 10$

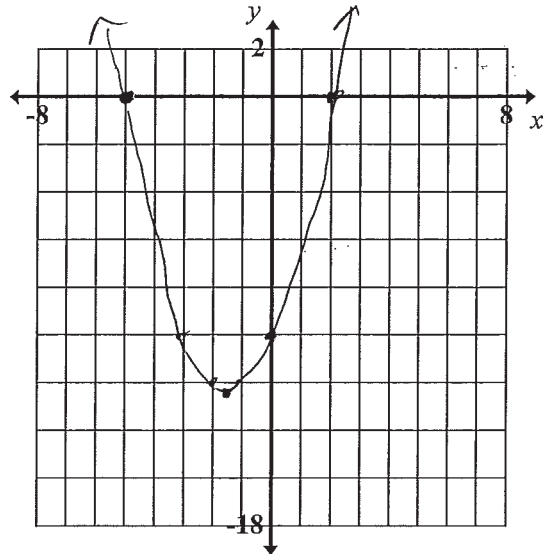
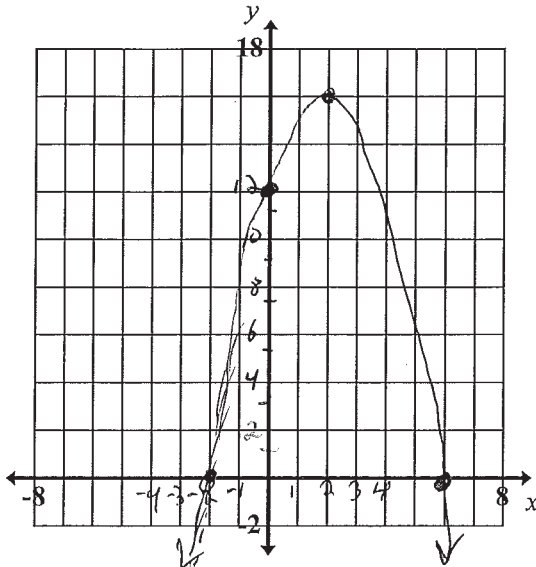

x	y
-5	-10
-2	-12
-1	-11
0	-10
1	-6
2	0
3	8

Solution(s): $x = -2, 6$

Solution(s): $x = -5, 2$

Verify: $f(-2) = -(-2)^2 + 4(-2) + 12$
 $= -(4) + -8 + 12$
 $= -4 + -8 + 12$
 $f(-2) = 0$
 $f(6) = -(6)^2 + 4(6) + 12$
 $f(6) = -36 + 24 + 12 = 0$

Verify: $f(-5) = (-5)^2 + 3(-5) - 10$
 $= 25 + -15 - 10 = 0$
 $f(2) = (2)^2 + 3(2) - 10$
 $= 4 + 6 - 10$
 $f(2) = 0$

#10 - 15: Use your graphing calculator to solve each equation by graphing. If needed, round your answer to the nearest hundredth. Question #13 - 15, verify that the values truly are solutions.

10. $x^2 - 7x = 11$
 $x^2 - 7x - 11 = 0$

11. $6x^2 = -19x - 15$
 $6x^2 + 19x + 15 = 0$

12. $5x^2 - 7x - 3 = 8$
 $5x^2 - 7x - 11 = 0$

Solution(s): $x = -1.32, 8.32$

Solution(s): $x = -1.6, -1.5$

Solution(s): $x = -0.94, 2.34$

13. $\frac{1}{2}x^2 - x = 8$
 $\frac{1}{2}x^2 - x - 8 = 0$

14. $x^2 + 4x = 6$
 $x^2 + 4x - 6 = 0$

15. $2x^2 - 2x - 5 = 0$

Solution(s): $x = -3.12, 5.12$

Solution(s): $x = -5.16, 1.16$

Solution(s): $x = -1.16, 2.16$

Verify: $f(-3.12) = (-3.12)^2 - (-3.12) - 8 \approx 0$
 $f(5.12) = (5.12)^2 - (5.12) - 8 \approx 0$

Verify: $(-5.16)^2 + 4(-5.16) = 5.99 \approx 6$
 $(1.16)^2 + 4(1.16) = 5.99 \approx 6$

Verify: $2(-1.16)^2 - 2(-1.16) - 5 = .01 \approx 0$
 $2(2.16)^2 - 2(2.16) - 5 = .01 \approx 0$

5.1A Solving Quadratic Equations by Graphing

#16 – 18: Use a graphing utility to graph the following functions. Draw the graph of the function. Use the graphing utility to approximate the zeros to the nearest tenth.

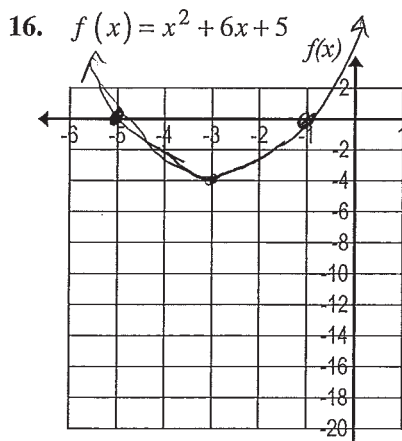

Solution(s): $-5, -1$

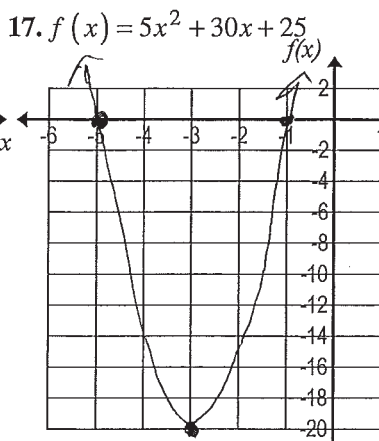

Solution(s): $-5, -1$

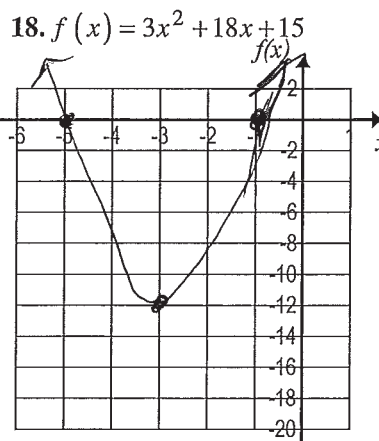

Solutions: $-5, -1$

#19 – 21: Use a graphing utility to graph the following functions. Draw the graph of the function. Use the graphing utility to approximate the zeros to the nearest tenth.

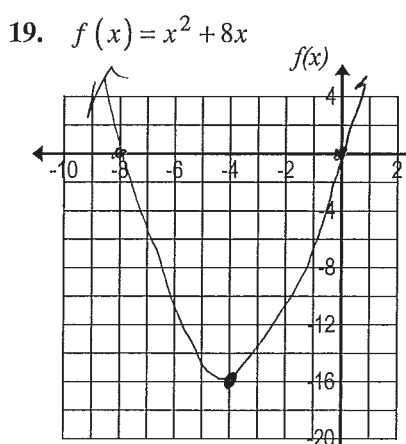

Solution(s): $0, -8$

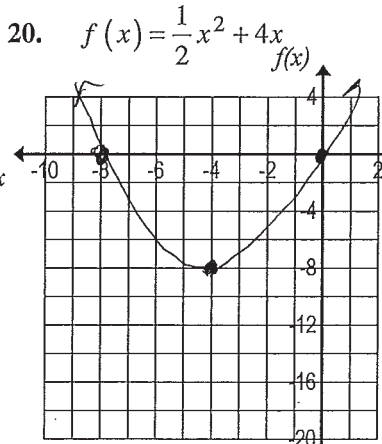

Solution(s): $0, -8$

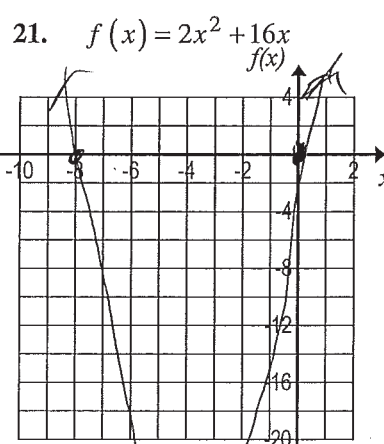

Solutions: $0, -8$

22. Investigation:

a) Looking to Question #16 – 18, record the following:

- Function in #16 $f(x) = x^2 + 6x + 5$ Solutions in #16 $x = -5, -1$
- Function in #17 $f(x) = 5x^2 + 30x + 25$ Solutions in #17 $x = -5, -1$
- Function in #18 $f(x) = 3x^2 + 18x + 15$ Solutions in #18 $x = -5, -1$

b) Looking to Question #19 – 21, record the following:

- Function in #19 $f(x) = x^2 + 8x$ Solutions in #19 $x = 0, -8$
- Function in #20 $f(x) = \frac{1}{2}x^2 + 4x$ Solutions in #20 $x = 0, -8$
- Function in #21 $f(x) = 2x^2 + 16x$ Solutions in #21 $x = 0, -8$

c) Comparing the functions in questions 16, 17, and 18, and then again in 19, 20, and 21, write a conjecture about the relationship of the functions within each set of questions and the solutions of those functions.

If one function is a multiple of another function, then they will have the same solutions.

5.1A Solving Quadratic Equations by Graphing

23. A bottlenose dolphin jumps out of the water. The path the dolphin travels can be modeled by the function $h(d) = -0.2d^2 + 2d$, where h represents the height, in feet, of the dolphin and d represents the horizontal distance, in feet, the dolphin traveled.

a) Sketch a graph of the quadratic equation.

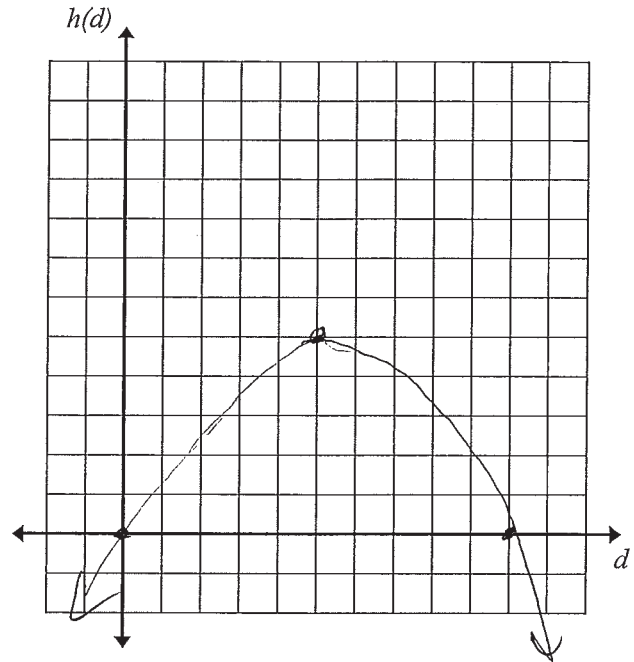

- b) What is the maximum height the dolphin reaches? Where is this represented on the graph of the function? *5 ft ; the vertex*
- c) What is the horizontal distance that the dolphin jumps? Where is this represented on the graph of the function? *10 ft ; the x intercept > 0*

Section 5.1A

5.1B Answering Real-World Questions by Graphing Quadratic Functions

#1 – 10: Use your graphing utility to solve the following problems.

1. Phillip, Peter and Pablo each throw a ball over a fence. The height of Phillip's ball with respect to time can be modeled by the equation $y = -16t^2 + 60t$. The height of Peter's ball with respect to time can be modeled by the equation $y = -16t^2 + 50t$. The height of Pablo's ball with respect to time can be modeled by the equation $y = -16t^2 + 40t$, where y is the height in feet and t is the time in seconds for each of the three models.

- a) Phillip, Peter and Pablo want to know whose ball hit the ground first. Peter thinks that they should find the x -intercept of the graphs to determine this. Phillip thinks that they should find the vertex of each graph to find which ball hit the ground first. Which one is correct? Explain your answer.

Peter is correct; the x int gives the time (t) when $y = 0$, which is where the ball has a height of 0 on the ground!

- b) Whose ball hit the ground first? How long did it take?

Pablo ; 2.5 sec

- c) Whose ball hit the ground second? How long did it take?

Peter ; 3.125 sec

2. A quarterback throws a football at an initial height of 5.5 feet with an initial upward velocity of 35 feet per second. The height of a tossed ball with respect to time can be modeled by the quadratic function $h(t) = -16t^2 + v_0 \cdot t + h_0$ where v_0 is the initial upward velocity, h_0 is the initial height and $h(t)$ is the height of the ball after t seconds.

- a) Write the function that models the height of the ball with respect to time.

$$h(t) = -16t^2 + 35t + 5.5$$

- b) How high will the football be after 1 second? (Consider what the 1 second represents.)

24.5 ft

(the 1 sec repr the x value)

- c) When will the football be 10 feet high? (Consider what the 10 feet represents.)

After 0.14 secs and again after 2.05 secs

(the 10 is the y value)

- d) When will the football reach its maximum height? (When graphing the function, consider what significant feature of the graph represents this concept.)

After 1.09 secs.

(At the vertex)

- e) What is the maximum height of the football?

24.64 ft

- f) When will the football hit the ground if no one catches it? (When graphing the function, consider what significant feature of the graph represents this concept.)

2.33 seconds

(the x int)

5.1B Answering Real-World Questions by Graphing Quadratic Functions

#1 – 10 (continued): Use your graphing utility to solve the following problems.

3. Suppose a batter hits a baseball, and the height of the baseball above the ground can be modeled by the function $h(t) = -16t^2 + 50t + 2$. Where is the vertex of the graph? Explain the meaning of the vertex in the context of this situation.
- Above the ground, the maximum y-value at (1.56, 41.06)*
- The vertex reveals how long it takes (1.56 sec) ^{the ball} to reach the maximum height (41.06 ft)*

4. A pool is treated with a chemical to reduce the amount of algae. The amount of algae in the pool t days after the treatment begins can be approximated by the function $A(t) = 4t^2 - 88t + 500$. How many days after treatment begins will the pool have the least amount of algae?

t = 11 days (the x coordinate of the vertex)

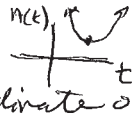

5. The driver of a car traveling downhill on a road applied the brakes. The speed of the car, $s(t)$, in kilometers per hour t seconds after the brakes were applied is modeled by the function rule $s(t) = -4t^2 + 12t + 80$.

- a) After how many seconds did the car reach its maximum speed?

1.5 secs

- b) What was the maximum speed reached?

89 km/h

- c) How long will it take the car to stop?

6.22 seconds

5.1B Answering Real-World Questions by Graphing Quadratic Functions

#1 – 10 (continued): Use your graphing utility to answer the following problems.

6. Andrew has 100 feet of fence to enclose a rectangular tomato patch. He wants to find the dimensions of the rectangle that encloses the most area. The width of the rectangle can be found by the expression $50 - L$ where L is the length of the rectangle.

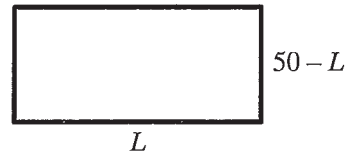

- a) In the expression representing the width of the rectangle ($50 - L$), what does the 50 represent? Explain your thinking clearly.

50 is half the perimeter, so one length + one width = 50.

- b) Write a function rule to model the area of the rectangle. $A(L)$ represents the Area of the rectangular tomato patch based on the length (L) of one side.

*$A(L) = L(50 - L)$
 $A(L) = -L^2 + 50L$*

- c) Find the coordinate representing the maximum of the graph. Explain its meaning in the context of the situation.

*(25, 625) when the length is 25, width is $50 - L = 25$
 $(L, A(L))$ $50 - 25 = 25$
 So Area = $l \times w$
 $= 25 \times 25$
 $= 625$
 $A(L) = 625$*

- d) What size should Andrew make the tomato patch in order to enclose the most area within the fencing?

a square shape, 25 ft x 25 ft

7. Sharon needs to create a fence for her new puppy. She purchased 40 feet of fencing to enclose the four sides of a rectangular play area.

- a) Determine the dimensions the enclosure play area should be to produce the **greatest** area for her puppy to play.

According to #6d, she should make a square with her 40 ft of fencing, so $40 \div 4 = 10$ ft on each side.

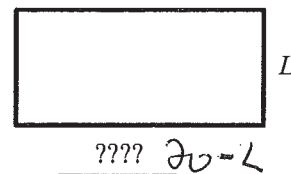

- b) Write a function rule to model the area of the play area.

*$A(L) = L(20 - L)$
 $A(L) = -L^2 + 20L$ Calc max shows vertex @ (10, 100)*

- c) What are the dimensions of the enclosure that will create the greatest area for her puppy to play?

*Length $L = 10$ ft
 width $20 - L = 10$ ft
 Area = 100 ft²*

5.1B Answering Real-World Questions by Graphing Quadratic Functions

#1 – 10 (continued): Use your graphing utility to answer the following problems.

8. Karen is throwing an orange to her brother Jim, who is standing on the balcony of their home. The height, h (in feet), of the orange above the ground t seconds after Karen throws the orange is given by the function $h(t) = -16t^2 + 32t + 3$. If Jim's outstretched arms are 16 feet above the ground, will the orange ever be high enough so that he can catch it? Explain your answer.

Yes! The max height of the orange is 19 ft, or the y coordinate of the vertex.
Jim can grab it either on the way up or the way down.

9. On wet concrete, the stopping distance, s (in feet), of a car traveling v miles per hour is given by $s(v) = 0.055v^2 + 1.1v$. At what speed could a car be traveling and still stop at a stop sign 30 feet away?

$(v, s(v))$
 $(v, 30)$
use Calc intersect $v \approx 15.41$ mph, so ≈ 15 mph

10. The Buckingham Fountain in Chicago shoots water from a nozzle at the base of the fountain. The height, in feet, of the water above the ground t seconds after it leaves the nozzle is given by $h(t) = -16t^2 + 90t + 15$.

- a) What is the maximum height of the water spout to the nearest tenth of a foot?

141.56 ft

- b) How long does it take for the water to hit the ground?

5.79 secs

Section 5.1B

5.2A Factoring Review#1 – 12: Factor out the greatest common factor (GCF) for each polynomial and write in *factored form*.

1. $2x+6$

$2x$	$+6$
------	------

Ans: $2(x+3)$

2. $3y-9$

$3y$	-9
------	------

Ans: $3(y-3)$

3. $7a+28$

$7a$	$+28$
------	-------

Ans: $7(a+4)$

4. $36z-12$

$36z$	-12
-------	-------

Ans: ~~$36z$~~ $12(3z-1)$

5. b^2+b

b^2	$+b$
-------	------

Ans: $b(b+1)$

6. $2r-r^2$

$2r$	$-r^2$
------	--------

Ans: $r(2-r)$

7. $9t^2+t$

$9t^2$	$+t$
--------	------

Ans: $t(9t+1)$

8. $4n^2-5n$

$4n^2$	$-5n$
--------	-------

Ans: $n(4n-5)$

9. $4h^2+12h$

$4h^2$	$+12h$
--------	--------

Ans: ~~$4h^2$~~ $4h(h+3)$

10. $9x-27x^2$

$9x$	$-27x^2$
------	----------

Ans: $9x(1-3x)$

11. $2a^2+4a$

$2a^2$	$+4a$
--------	-------

Ans: $2a(a+2)$

12. $20d^2-24d$

$20d^2$	$-24d$
---------	--------

Ans: $4d(5d-6)$

#13 – 27: Factor each polynomial.

13. $x^2+13x+42$

Ans: $(x+7)(x+6)$

14. x^2+6x+9

Ans: $(x+3)(x+3)$

15. $x^2+12x+32$

Ans: $(x+8)(x+4)$

16. $x^2+3x-10$

Ans: $(x+5)(x-2)$

17. $x^2-10x+25$

Ans: $(x-5)(x-5)$

18. x^2-x-12

Ans: $(x-4)(x+3)$

19. $3x^2+x-4$

Ans: $(3x+4)(x-1)$

20. $2x^2+5x-12$

Ans: $(2x-3)(x+4)$

21. $4x^2-12x+9$

Ans: $(2x-3)(2x-3)$

5.2A Factoring Review

#13 – 27 (continued): Factor each polynomial.

22. $12x^2 - 8x + 1$

23. $2x^2 - 8x - 10$

24. $3x^2 + 21x + 18$

$2(x^2 - 4x - 5)$

$3(x^2 + 7x + 6)$

Ans: $(6x-1)(2x-1)$

Ans: $2(x+1)(x-5)$

Ans: $3(x+1)(x+6)$

25. $a^2 - 9$

26. $x^2 - 16$

27. $25x^2 - 36$

Ans: $(a+3)(a-3)$

Ans: $(x+4)(x-4)$

Ans: $(5x+6)(5x-6)$

#28-29: The following quadratic functions are written in standard form. Convert them to factored form.

28. $y = x^2 + 3x + 2$

29. $y = x^2 - 49$

$y = (x+1)(x+2)$

$y = (x+7)(x-7)$

30. Why is factored form of a quadratic function also called intercept form?

x -intercepts have a y -coordinate of 0.
Setting $y=0$ and easily solving for x gives the solution(s), which are the x -intercept(s).

#31 – 32: Convert the following quadratic functions to factored form and identify the x -intercepts.

31. $y = x^2 - 24x + 80$

32. $y = x^2 + 9x - 10$

$0 = (x-4)(x-20)$

$0 = (x-1)(x+10)$

 x -intercepts: 4 and 20 x -intercepts: 1 and -10

33. The parabola graphed below shows the height of a ball tossed into the air.

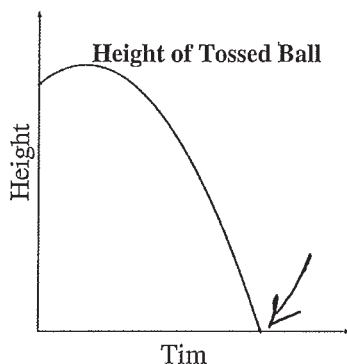

a) Draw an arrow to the location of the graph that would represent when the ball hits the ground?

b) Explain why you placed the arrow at that location.

 $y=0$ means the ground level.

Section 5.2A

5.2B Solve Quadratic Equations by Factoring: Part I

#1 - 3: Solve for x.

1. $(x-4)(x+9)=0$
 $x=4$ or -9

2. $(x-2)(3x-6)=0$
 $x=2$ (double root)

3. $(4x+3)(2x-5)=0$
 $x=-\frac{3}{4}$ or $\frac{5}{2}$

#4 - 17: Factor the quadratic expression then solve the equation by factoring. Verify your solution(s).

4. $4x^2 - 36 = 0$
 $4(x^2 - 9) = 0$
 $4(x+3)(x-3) = 0$
 $x = -3$ or 3
 $4(-3)^2 - 36 = 0$ ✓
 $4(3)^2 - 36 = 0$ ✓
 $4 \cdot 9 - 36$

✓ Verify your solution(s):

5. $5x^2 - 20 = 0$
 $5(x^2 - 4) = 0$
 $5(x+2)(x-2) = 0$
 $x = -2$ or 2
 $5(-2)^2 - 20 = 0$ ✓
 $5(2)^2 - 20 = 0$ ✓

✓ Verify your solution(s):

6. $3x^2 - 9x = 0$
 $3x(x-3) = 0$
 $x = 0$ or $x = 3$
 $3(0)^2 - 9(0) = 0$ ✓
 $3(3)^2 - 9(3) = 0$ ✓

✓ Verify your solution(s):

7. $7x^2 - 28x = 0$
 $7x(x-4) = 0$
 $x = 0$ or 4

✓ Verify your solution(s):

$7(0)^2 - 28(0) = 0$ ✓
 $7(4)^2 - 28(4)$
 $7(16) - 28(4)$
 $112 - 112 = 0$ ✓

8. $x^2 + 8x - 9 = 0$
 $(x+9)(x-1) = 0$
 $x = -9$ or $x = 1$

✓ Verify your solution(s):

$(-9)^2 + 8(-9) - 9 = 0$ ✓
 $81 - 72 - 9 = 0$ ✓
 $(1)^2 + 8(1) - 9 = 0$ ✓
 $1 + 8 - 9 = 0$ ✓

9. $x^2 + 7x + 12 = 0$
 $(x+4)(x+3) = 0$
 $x = -4$ or -3

✓ Verify your solution(s):

$(-4)^2 + 7(-4) + 12 = 0$ ✓
 $16 - 28 + 12 = 0$ ✓
 $(-3)^2 + 7(-3) + 12 = 0$ ✓
 $9 - 21 + 12 = 0$ ✓

5.2B Solve Quadratic Equations by Factoring: Part I

#4 – 17 (continued): Factor the quadratic expression then solve the equation by factoring. Verify your solution(s).

10. $x^2 - 10x + 25 = 0$

$$(x-5)(x-5) = 0$$

$$\boxed{x = 5}$$

✓ Verify your solution(s):

$$(5)^2 - 10(5) + 25 = 0$$

$$25 - 50 + 25 = 0 \checkmark$$

11. $x^2 - 3x = 4$

$$x^2 - 3x - 4 = 0$$

$$(x+1)(x-4) = 0$$

$$\boxed{x = -1, 4}$$

✓ Verify your solution(s):

$$(-1)^2 - 3(-1) = 4 \checkmark$$

$$1 + 3 = 4 \checkmark$$

$$(4)^2 - 3(4) = 4 \checkmark$$

$$16 - 12 = 4 \checkmark$$

12. $x^2 - 4x = 5$

$$x^2 - 4x - 5 = 0$$

$$(x+1)(x-5) = 0$$

$$\boxed{x = -1, 5}$$

✓ Verify your solution(s):

$$(-1)^2 - 4(-1) = 5 \checkmark$$

$$1 + 4 = 5 \checkmark$$

$$(5)^2 - 4(5) = 5 \checkmark$$

$$25 - 20 = 5 \checkmark$$

13. $x^2 - 13x = -40$

$$x^2 - 13x + 40 = 0$$

$$(x-8)(x-5) = 0$$

$$\boxed{x = 8, 5}$$

✓ Verify your solution(s):

$$(8)^2 - 13(8) = -40 \checkmark$$

$$64 - 104 = -40 \checkmark$$

$$(5)^2 - 13(5) = -40 \checkmark$$

$$25 - 65 = -40 \checkmark$$

14. $3x^2 + 10x + 8 = 0$

$$(3x+4)(x+2) = 0$$

$$\boxed{x = -\frac{4}{3}, -2}$$

✓ Verify your solution(s):

$$3\left(-\frac{4}{3}\right)^2 + 10\left(-\frac{4}{3}\right) + 8 = 0 \checkmark$$

$$\frac{3 \cdot 16}{9} - \frac{40}{3} + \frac{24}{3} = 0 \checkmark$$

$$\frac{16}{3} - \frac{40}{3} + \frac{24}{3} = 0 \checkmark$$

$$3(-2)^2 + 10(-2) + 8 = 0 \checkmark$$

15. $8x^2 + 6x - 5 = 0$

$$(4x+5)(2x-1) = 0$$

$$\boxed{x = -\frac{5}{4}, \frac{1}{2}}$$

✓ Verify your solution(s):

$$8\left(-\frac{5}{4}\right)^2 + 6\left(-\frac{5}{4}\right) - 5 = 0 \checkmark$$

$$8 \cdot \frac{25}{16} - \frac{15}{2} - 5 = 0 \checkmark$$

$$\frac{25}{2} - \frac{15}{2} - 5 = 0 \checkmark$$

$$8\left(\frac{1}{2}\right)^2 + 6\left(\frac{1}{2}\right) - 5 = 0 \checkmark$$

$$8\left(\frac{1}{4}\right) + 3 - 5 = 0 \checkmark$$

$$2 + 3 - 5 = 0 \checkmark$$

16. $5x^2 + 11x = -2$

$$5x^2 + 11x + 2 = 0$$

$$(5x+1)(x+2) = 0$$

$$\boxed{x = -\frac{1}{5}, -2}$$

✓ Verify your solution(s):

$$5\left(-\frac{1}{5}\right)^2 + 11\left(-\frac{1}{5}\right) + 2 = 0 \checkmark$$

$$5 \cdot \frac{1}{25} - \frac{11}{5} + \frac{10}{5} = 0 \checkmark$$

$$\frac{1}{5} - \frac{11}{5} + \frac{10}{5} = 0 \checkmark$$

$$5(-2)^2 + 11(-2) = -2 \checkmark$$

$$20 - 22 + 2 = -2 \checkmark$$

17. $2x^2 - 15x = 8$

$$2x^2 - 15x - 8 = 0$$

$$(2x+1)(x-8) = 0$$

$$\boxed{x = -\frac{1}{2}, 8}$$

✓ Verify your solution(s):

$$2\left(-\frac{1}{2}\right)^2 - 15\left(-\frac{1}{2}\right) = 8 \checkmark$$

$$2\left(\frac{1}{4}\right) + \frac{15}{2} = \frac{16}{2} \checkmark$$

$$\frac{1}{2} + \frac{15}{2} = \frac{16}{2} \checkmark$$

$$2(8)^2 - 15(8) = 8 \checkmark$$

$$128 - 120 = 8 \checkmark$$

Section 5.2B

5.2C Solve Quadratic Equations by Factoring: Part II

#1 – 9: Solve the following application problems.

1. One leg of a right triangle is 1 foot longer than the other leg. The hypotenuse is 5 feet. Find the dimensions of the right triangle.

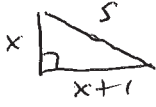

$$x^2 + (x+1)^2 = 25$$

$$x^2 + x^2 + 2x + 1 = 25$$

$$2x^2 + 2x - 24 = 0$$

$$2(x^2 + x - 12) = 0$$

$$2(x+4)(x-3) = 0$$

extraneous $x = -4$ $x = 3 \Rightarrow$ 2 legs are 3 & $(3+1)$
 legs = 3 & 4

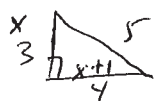

✓Verify your solution(s):

$$3^2 + 4^2 = 5^2$$

$$9 + 16 = 25 \checkmark$$

2. One leg of a right triangle is 7 feet longer than the other leg. The hypotenuse is 13. Find the dimensions of the right triangle.



$$x^2 + (x+7)^2 = 13^2$$

$$x^2 + x^2 + 14x + 49 = 169$$

$$2x^2 + 14x - 120 = 0$$

$$2(x^2 + 7x - 60) = 0$$

$$2(x+12)(x-5) = 0$$

~~$x = -12$~~ $x = 5 \Rightarrow$
 2 legs are 5 & 12

✓Verify your solution(s):

$$5^2 + 12^2 = 13^2$$

$$25 + 144 = 169 \checkmark$$

3. A rectangle has sides of $x+2$ and $x-1$. What value of x gives an area of 108?

$$(x+2)(x-1) = 108$$

$$x^2 + x - 2 - 108 = 0$$

$$x^2 + x - 110 = 0$$

$$(x-10)(x+11) = 0$$

$x = 10$ $x = -11$
 extraneous

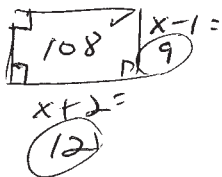

✓Verify your solution(s): $12 \times 9 = 108 \checkmark$

4. A rectangle has sides of $x-1$ and $x+1$. What value of x gives an area of 120?

$$(x-1)(x+1) = 120$$

$$x^2 - 1 - 120 = 0$$

$$x^2 - 121 = 0$$

$$(x+11)(x-11) = 0$$

~~$x = -11$~~ $x = 11$

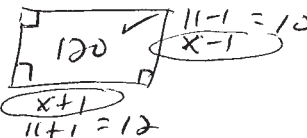

✓Verify your solution(s):

$$11+1 = 12$$

5. The product of two positive numbers is 120. Find the two numbers if one number is 7 more than the other.

$$x(x+7) = 120$$

$$x^2 + 7x - 120 = 0$$

$$(x-8)(x+15) = 0$$

$x = 8$ or $x = -15$

$x = 8$, $x+7 = 15$
 $8(15) = 120 \checkmark$

✓Verify your solution(s):

5.2C Solve Quadratic Equations by Factoring: Part II

6. A rectangle has a 50-foot diagonal. What are the dimensions of the rectangle if it is 34 feet longer than it is wide?

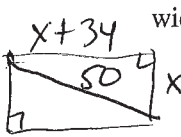

$x^2 + (x+34)^2 = 50^2$
 $x^2 + x^2 + 68x + 1156 = 2500$
 $2x^2 + 68x - 1344 = 0$
 $2(x^2 + 34x - 672) = 0$
 $2(x-14)(x+48) = 0$
 $x = 14$ $x = -48$

Verify your solution(s):
 $14^2 + 48^2 = 50^2$
 $196 + 2304 = 2500$ ✓

The dimensions are 14' by 48'

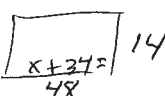

7. Two positive numbers have a sum of 8, and their product is equal to the larger-number plus 10. What are the numbers?

Let $x = 1^{st}$ #
 $8-x = 2^{nd}$ #
 $8 = sum$

$x(8-x) = x+10$
 $8x - x^2 = x+10$
 $0 = x^2 - 7x + 10$
 $0 = (x-5)(x-2)$
 $x = 5$ or $x = 2$
 verify each

Verify your solution(s):
 If 1^{st} # $x = 5$, 2^{nd} # is $8-5 = 3$
 Product $5(3) = 5+10$ ✓
 So 2 #s are 5 + 3

If 1^{st} # $x = 2$, 2^{nd} # = 6 $2+6=8$
 But $2(6) \neq 6+10$ No.

So the 2 positive #s are 5 and 3

8. The product of two negative integers is 24. The difference between the integers is 2. Find the integers.

Let $x = one\ integer\ neg$
 $x+2 = 2^{nd}\ integer\ neg$

Then $x(x+2) = 24$
 $x^2 + 2x - 24 = 0$
 $(x-4)(x+6) = 0$ ✓ Verify your solution(s):
 $x = 4$ or $x = -6$ \implies ?
 $x = -6$ are the 2 negative ints.
 $x+2 = -4$
 $(-6)(-4) = 24$

Extraneous

9. Framing Warehouse offers a picture framing service. The cost for framing a picture is made up of two parts: glass costs \$1 per square foot and the frame costs \$2 per linear foot. If the frame has to be a square, what size picture can you get framed for \$20?

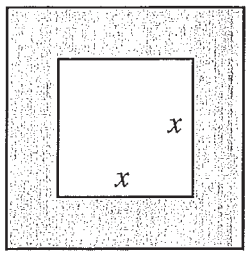

linear price $\$2(4x) = 8x$
 perimeter $\$1x^2$
 $x^2 + 8x = 20$
 $x^2 + 8x - 20 = 0$
 $(x+10)(x-2) = 0$
 $x = 10$ $x = 2$

area glass $\$1x^2$

You can frame a 2ft by 2ft square picture

Verify your solution(s):
 When $x=2$, $P = 8 \times 2 = 16$
 glass area $2 \times 2 = 4 \text{ ft}^2 \times 1 = 4$
 $16 + 4 = 20$ ✓

5.2D Operations with Radical Expressions

1. Simplify each expression.

a) $\frac{\sqrt{20}}{\sqrt{4.5}}$
 $2\sqrt{5}$

b) $\frac{\sqrt{48}}{\sqrt{6.3}}$
 $4\sqrt{3}$

c) $\frac{\sqrt{200}}{\sqrt{100.2}}$
 $10\sqrt{2}$

d) $3\sqrt{20}$
 $3\sqrt{4.5}$
 $3 \cdot 2\sqrt{5}$
 $6\sqrt{5}$

e) $5\sqrt{24}$
 $5\sqrt{4.6}$
 $5 \cdot 2\sqrt{6}$
 $10\sqrt{6}$

f) $6\sqrt{98}$
 $6\sqrt{49.2}$
 $6 \cdot 7\sqrt{2}$
 $42\sqrt{2}$

2. Add or subtract each expression.

a) $(5 - \sqrt{3}) + (4 + \sqrt{3})$
 9

b) $(4 + 5\sqrt{2}) + (2 + 6\sqrt{2})$
 $6 + 11\sqrt{2}$

c) $(6 - 8\sqrt{7}) - (4 + 2\sqrt{7})$
 $2 - 10\sqrt{7}$

d) $8 - (3 + 5\sqrt{2})$
 $5 - 5\sqrt{2}$

e) $-2\sqrt{5} + (3 + \sqrt{5})$
 $3 - \sqrt{5}$

f) $(6 + 5\sqrt{12}) + (5 - \sqrt{12})$
 $11 + 4\sqrt{12}$
 $11 + 4\sqrt{4.3}$
 $11 + 4 \cdot 2\sqrt{3}$
 $11 + 8\sqrt{3}$

5.2D Operations with Radical Expressions

3. Simplify each using two different methods.

a) $\sqrt{2} \cdot \sqrt{18}$

1 st method	2 nd method
$\begin{aligned} &\sqrt{2} \cdot \sqrt{18} \\ &\sqrt{2 \cdot 18} \\ &\sqrt{36} \\ &6 \end{aligned}$	$\begin{aligned} &\sqrt{2} \cdot \sqrt{18} \\ &\sqrt{2} \cdot \sqrt{9 \cdot 2} \\ &\sqrt{2} \cdot \sqrt{9} \cdot \sqrt{2} \\ &3 \cdot 2 = 6 \end{aligned}$

b) $\sqrt{8} \cdot \sqrt{2}$

1 st method	2 nd method
$\begin{aligned} &\sqrt{8} \cdot \sqrt{2} \\ &\sqrt{8 \cdot 2} \\ &\sqrt{16} \\ &4 \end{aligned}$	$\begin{aligned} &\sqrt{8} \cdot \sqrt{2} \\ &\sqrt{4 \cdot 2} \cdot \sqrt{2} \\ &\sqrt{4} \sqrt{2} \sqrt{2} \\ &2 \cdot 2 \\ &4 \end{aligned}$

4. Simplify each expression.

a) $\sqrt{5} \cdot \sqrt{5}$
5

b) $\sqrt{5} \cdot \sqrt{18}$
 $\sqrt{5} \sqrt{9} \sqrt{2}$
 $3\sqrt{10}$

c) $\sqrt{6} \cdot \sqrt{3}$
 $\sqrt{18}$
 $\sqrt{9 \cdot 2}$
 $3\sqrt{2}$

d) $3\sqrt{20} \cdot 2\sqrt{3}$
 $6\sqrt{60}$
 $6\sqrt{4 \cdot 15}$
 $6 \cdot 2\sqrt{15}$
 $12\sqrt{15}$

e) $-5\sqrt{2} \cdot 8\sqrt{2}$
 $-40 \cdot 2$
 -80

f) $-2\sqrt{6} \cdot 3\sqrt{7}$
 $-6\sqrt{42}$

5.2D Operations with Radical Expressions

5. Simplify each expression.

a)
$$\frac{5(3+\sqrt{7})}{15+5\sqrt{7}}$$

b)
$$\frac{-3(2-\sqrt{3})}{-6+3\sqrt{3}}$$

c)
$$\frac{2(1+4\sqrt{3})}{2+8\sqrt{3}}$$

d)
$$\frac{\sqrt{5}(2+3\sqrt{2})}{2\sqrt{5}+3\sqrt{10}}$$

e)
$$\frac{-\sqrt{2}(3+\sqrt{18})}{-3\sqrt{2}-\sqrt{36}}$$

$$-3\sqrt{2}-6$$

$$-6-3\sqrt{2}$$

f)
$$\frac{-\sqrt{3}(5-\sqrt{8})}{-5\sqrt{3}+\sqrt{24}}$$

$$\sqrt{4 \cdot 6}$$

$$-5\sqrt{3}+2\sqrt{6}$$

6. Simplify each expression.

a)
$$(4+\sqrt{3})(4+\sqrt{3})$$

$$16+8\sqrt{3}+3$$

$$19+8\sqrt{3}$$

b)
$$2(3-\sqrt{2})^2$$

$$2(3-\sqrt{2})(3-\sqrt{2})$$

$$2(9-6\sqrt{2}+2)$$

$$2(11-6\sqrt{2})$$

$$22-12\sqrt{2}$$

c)
$$5(2-\sqrt{3})^2+6(2-\sqrt{3})$$

$$5(2-\sqrt{3})(2-\sqrt{3})+12-6\sqrt{3}$$

$$5(4-4\sqrt{3}+3) \quad \downarrow \quad \downarrow$$

$$5(7-4\sqrt{3})$$

$$35-20\sqrt{3}+12-6\sqrt{3}$$

$$47-26\sqrt{3}$$

d)
$$4(1+3\sqrt{2})(1+3\sqrt{2})$$

$$4(1+6\sqrt{2}+18)$$

$$4(19+6\sqrt{2})$$

$$76+24\sqrt{2}$$

e)
$$3(4-2\sqrt{7})^2$$

$$3(4-2\sqrt{7})(4-2\sqrt{7})$$

$$3(16-16\sqrt{7}+28)$$

$$3(44-16\sqrt{7})$$

$$132-48\sqrt{7}$$

f)
$$3(2-\sqrt{11})^2-5(2-\sqrt{11})+7$$

$$3(2-\sqrt{11})(2-\sqrt{11})-10+5\sqrt{11}+7$$

$$3(4-4\sqrt{11}+11)$$

$$3(15-4\sqrt{11})$$

$$45-12\sqrt{11}-3+5\sqrt{11}$$

$$42-7\sqrt{11}$$

5.2D Operations with Radical Expressions

7. Verify that the given answer (value of x) is a solution to the equation.

a) $x^2 + 7 = 25; x = 3\sqrt{2}$
 $(3\sqrt{2})^2 + 7 = 25$
 $18 + 7 = 25 \checkmark$

yes

b) $x^2 - 14x + 50 = 3; x = (6 + \sqrt{2})$
 $(6 + \sqrt{2})(6 + \sqrt{2}) - 14(6 + \sqrt{2}) + 50 = 3$
 $36 + 12\sqrt{2} + 2 - 84 - 14\sqrt{2} + 50 = 3$
 $38 + 12\sqrt{2} - 84 - 14\sqrt{2} + 50$
 $4 - 2\sqrt{2} \neq 3$
 $6 + \sqrt{2}$ is not a solution

c) $\frac{2x^2 - 20x}{2} = \frac{40}{2}; x = (5 - 3\sqrt{5})$
 $x^2 - 10x = 20$
 $x^2 - 10x - 20 = 0$
 $(5 - 3\sqrt{5})(5 - 3\sqrt{5}) - 10(5 - 3\sqrt{5}) - 20 = 0$
 $25 - 30\sqrt{5} + 45 - 50 + 30\sqrt{5} - 20 = 0$
 $70 - 70 - 30\sqrt{5} + 30\sqrt{5} = 0$
 $0 = 0 \checkmark$

yes

8. Simplify each expression.

a) $\frac{6a + 15}{3}$
 $2a + 5$

b) $\frac{6 + 15\sqrt{2}}{3}$
 $2 + 5\sqrt{2}$

c) $\frac{-14 - 10\sqrt{6}}{2}$
 $-7 - 5\sqrt{6}$

d) $\frac{-25 + 15\sqrt{40}}{5}$
 $-5 + 3\sqrt{40}$
 $3\sqrt{4 \cdot 10}$
 $5 + 6\sqrt{10}$

9. Verify that the given answer (value of x) is a solution to the equation.

$2x^2 - 3x - 6 = 0; x = \frac{3 + \sqrt{57}}{4}$
 $2\left(\frac{3 + \sqrt{57}}{4}\right)^2 - 3\left(\frac{3 + \sqrt{57}}{4}\right) - 6 = 0$
 $\frac{9 + 6\sqrt{57} + 57}{16}$
 $\left(\frac{66 + 6\sqrt{57}}{16}\right)$
 $2\left(\frac{33 + 3\sqrt{57}}{8}\right)$
 $\frac{33 + 3\sqrt{57}}{4} - \frac{9 + 3\sqrt{57}}{4}$
 $\frac{24}{4} - 6 = 0$
 $0 = 0 \checkmark$

Section 5.2D

5.2E Solve Quadratic Equations Using Square Roots to Find Rational Solutions

#1 - 6: Solve each equation using the square root property and check each answer.

1. $\sqrt{x^2} = \sqrt{4}$

$|x| = 2$

$x = \pm 2$

$(2)^2 = 4 \checkmark$
 $(-2)^2 = 4 \checkmark$

✓ Verify your solution(s):

$(2)^2 = 4 \checkmark$
 $(-2)^2 = 4 \checkmark$

2. $2a^2 = 32$
 $\sqrt{a^2} = \sqrt{16}$

$|a| = 4$

$a = \pm 4$

$2(4)^2 = 2(16) = 32 \checkmark$

$2(-4)^2 = 2(16) = 32 \checkmark$

✓ Verify your solution(s):

3. $3m^2 - 8 = 67$

$3m^2 = 75$

$\sqrt{m^2} = \sqrt{25}$

$|m| = 5$

$m = \pm 5$

$3(5)^2 - 8 = 67 \checkmark$
 $75 - 8 = 67 \checkmark$

$3(-5)^2 - 8 = 67 \checkmark$
 $75 - 8 = 67 \checkmark$

✓ Verify your solution(s):

4. $\sqrt{(x-1)^2} = \sqrt{36}$

$|x-1| = 6$

$x-1 = 6$ or $x-1 = -6$

$x = 7$ or $x = -5$

✓ Verify your solution(s):

$(7-1)^2 = 36$
 $6^2 = 36 \checkmark$

$(-5-1)^2 = 36$

$(-6)^2 = 36 \checkmark$

5. $(x+3)^2 - 16 = 0$

$\sqrt{(x+3)^2} = \sqrt{16}$

$|x+3| = 4$

$x+3 = 4$ or $x+3 = -4$

$x = 1$ or $x = -7$

✓ Verify your solution(s):

$(1+3)^2 - 16 = 0$ $(-7+3)^2 - 16 = 0$

$4^2 - 16 = 0$ $(-4)^2 - 16 = 0$

$16 - 16 = 0 \checkmark$ $16 - 16 = 0 \checkmark$

6. $2(x-2)^2 + 3 = 21$

$2(x-2)^2 = 18$

$(x-2)^2 = 9$

$\sqrt{(x-2)^2} = \sqrt{9}$

$|x-2| = 3$

$x-2 = 3$ or $x-2 = -3$

$x = 5$ or $x = -1$

✓ Verify your solution(s):

$2(5-2)^2 + 3 = 21$ $2(-1-2)^2 + 3 = 21$

$2(3)^2 + 3 = 21 \checkmark$ $2(-3)^2 + 3 = 21 \checkmark$

$18 + 3 = 21 \checkmark$ $18 + 3 = 21 \checkmark$

5.2E Solve Quadratic Equations Using Square Roots to Find Rational Solutions

7. A physics teacher drops an object from an initial height of 64 feet. The height of the ball (in feet) h at time t (in seconds) can be modeled by the equation $h(t) = -16t^2 + 64$.

How long does it take the ball to reach the ground?

$$\begin{aligned} -16t^2 + 64 &= 0 \\ -16t^2 &= -64 \\ \sqrt{t^2} &= \sqrt{4} \end{aligned}$$

$$|t| = 2$$

$t = 2$ seconds or $t = -2$ extraneous

$$\begin{aligned} -16(2)^2 + 64 &= 0 \\ -16(4) & \\ -64 + 64 &= 0 \checkmark \end{aligned}$$

✓ Verify your solution(s):

2 seconds



8. The stopping distance “ d ” (in meters) that a car needs to come to a complete stop when traveling at speed “ x ” (in km/h) can be modeled by the equation $d = 0.009(x+15)^2 + 3$. On a certain road, drivers cannot see a stop sign until they are approximately 20 meters away. What is the maximum speed that should be posted in order to allow cars enough room to stop in time? Round your answer to the nearest whole number and verify your solution.



$$\begin{aligned} 20 &= 0.009(x+15)^2 + 3 \\ 17 &= 0.009(x+15)^2 \\ \frac{17}{0.009} &= \frac{0.009(x+15)^2}{0.009} \\ \sqrt{1888.\bar{8}} &= \sqrt{(x+15)^2} \\ 43.4613 &= |x+15| \\ x+15 &= 43.4613 \text{ or } x+15 = -43.4613 \\ x &\approx 28 \quad \text{or } x \approx -58 \text{ extraneous} \end{aligned}$$

$$\begin{aligned} &.009(28+15)^2 + 3 \\ &(43)^2 \\ (0.009)1849 + 3 &\approx 19.6 \approx 20 \checkmark \\ &28 \text{ Km/h} \end{aligned}$$

9. A missing leg of a right triangle can be found using the Pythagorean Theorem: $a^2 + b^2 = c^2$, where “ a ” and “ b ” are the legs of the triangle and “ c ” is the hypotenuse of the triangle (the side directly across from the right angle). Andy is trying to find the missing leg of the triangle below that represents the distance that the person is from a flagpole. The flag pole is 12 feet tall and he knows that the distance from the person to the top of the flagpole is 15 feet. Andy has started the problem by putting the values into the formula. Help him find the solution.

$$a^2 + b^2 = c^2$$

$$\begin{aligned} (12)^2 + b^2 &= (15)^2 \\ 144 + b^2 &= 225 \\ \sqrt{b^2} &= \sqrt{81} \\ |b| &= 9 \\ b &= 9 \quad b = -9 \end{aligned}$$

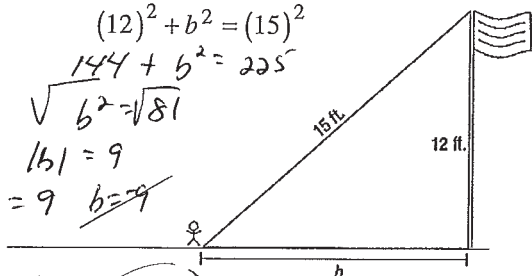

Other leg is 9 ft

Section 5.2E

5.2F Solve Quadratic Equations Using Square Roots to Find Real Solutions

1. On a quiz, Omar solved a quadratic equation and got the answer wrong. His work is shown below. Identify his mistake and then solve the equation correctly to find the real solution.

$$\sqrt{(x-3)^2} = \sqrt{9}$$

$$|x-3| = 3$$

$$x-3 = 3 \text{ or } x-3 = -3$$

$$x = 6 \text{ or } x = 0$$

$$12) \frac{2(x-3)^2}{2} = \frac{18}{2}$$

$$(x-3)^2 = 9$$

error here $\rightarrow +3 +3$

$$\sqrt{x^2} = \sqrt{12}$$

$$x = 3.464, -3.464$$

#2 - 5: Verify that each of the following values are solutions to the given equation. Show ALL of your work.

2. $2x^2 + 3 = 21$; $x = 3, x = -3$

$$2(3)^2 + 3 = 21$$

$$2(-3)^2 + 3 = 21$$

$$2(9) + 3 = 21 \checkmark$$

$$18 + 3 = 21 \checkmark$$

3. $(x-5)^2 + 1 = 17$; $x = 9, x = 1$

$$(9-5)^2 + 1 = 17$$

$$(1-5)^2 + 1 = 17$$

$$(4)^2 + 1 = 17 \checkmark$$

$$16 + 1 = 17 \checkmark$$

$$(-4)^2 + 1 = 17 \checkmark$$

$$16 + 1 = 17 \checkmark$$

4. $x^2 + 7 = 35$; $x = 2\sqrt{7}, x = -2\sqrt{7}$

$$(2\sqrt{7})^2 + 7 = 35$$

$$(-2\sqrt{7})^2 + 7 = 35$$

$$4 \cdot 7 + 7 = 35 \checkmark$$

$$4 \cdot 7 + 7 = 35 \checkmark$$

5. $(x+3)^2 - 5 = 70$; $x = -3 + \sqrt{5}, x = -3 - \sqrt{5}$

$$((-3 + \sqrt{5}) + 3)^2 - 5 = 70$$

$$(\sqrt{5})^2 - 5 = 70$$

$$5 - 5 \neq 70$$

$(-3 + \sqrt{5})$ is NOT a soln.

$$((-3 - \sqrt{5}) + 3)^2 - 5 = 70$$

$$(-\sqrt{5})^2 - 5 = 70$$

$$5 - 5 \neq 70$$

$(-3 - \sqrt{5})$ is NOT a soln.

5.2F Solve Quadratic Equations Using Square Roots to Find Real Solutions

#7 – 10 (continued): Solve each equation for real solutions and simplify your answers. Verify your solutions!

9. $2x^2 - 8 = 0$

$$2x^2 = 8$$
$$\sqrt{x^2} = \sqrt{4}$$

$$|x| = 2$$

$$x = \pm 2$$

10. $5(x-1)^2 - 3 = 42$

$$5(x-1)^2 = 45$$
$$\sqrt{(x-1)^2} = \sqrt{9}$$

$$|x-1| = 3$$

$$x-1 = 3 \quad \text{or} \quad x-1 = -3$$
$$+1 \quad +1 \qquad \qquad +1 \quad +1$$

$$x = 4 \quad \text{or} \quad x = -2$$

✓ Verify your solution(s):

$$2(2)^2 - 8 = 0$$

$$2 \cdot 4 - 8 = 0 \quad \checkmark$$

$$2(-2)^2 - 8$$

$$2(4) - 8 = 0 \quad \checkmark$$

✓ Verify your solution(s):

$$5(4-1)^2 - 3$$

$$5(3)^2 - 3$$

$$5 \cdot 9 - 3 = 42 \quad \checkmark$$

$$5(-2-1)^2 - 3 = 42$$

$$5(-3)^2 - 3$$

$$5 \cdot 9 - 3 = 42 \quad \checkmark$$

#11 – 14: Find the roots of each function and simplify your answers. Verify your solutions!

11. $f(x) = x^2 - 75$

$$x^2 - 75 = 0$$

$$\sqrt{x^2} = \sqrt{75}$$

$$|x| = \sqrt{25 \cdot 3}$$

$$x = \pm 5\sqrt{3}$$

12. $f(x) = (x+2)^2$

$$\sqrt{(x+2)^2} = \sqrt{0}$$

$$|x+2| = 0$$

$$x+2 = 0$$

$$-2 \quad -2$$

$$x = -2$$

✓ Verify your solution(s):

$$(5\sqrt{3})^2 - 75 = 0$$

$$25 \cdot 3 - 75 = 0 \quad \checkmark$$

$$(-5\sqrt{3})^2$$

$$25 \cdot 3 - 75 = 0 \quad \checkmark$$

✓ Verify your solution(s):

$$(-2+2)^2 = 0$$

$$0^2 = 0 \quad \checkmark$$

5.2F Solve Quadratic Equations Using Square Roots to Find Real Solutions

#11 – 14 (continued): Find the roots of each function and simplify your answers. Verify your solutions!

13. $f(x) = 2(x-1)^2 - 18$

$$2(x-1)^2 - 18 = 0$$

$$2(x-1)^2 = 18$$

$$(x-1)^2 = 9$$

$$\sqrt{(x-1)^2} = \sqrt{9}$$

$$|x-1| = 3$$

$$x-1 = 3 \text{ or } x-1 = -3$$

$$x = 4 \text{ or } x = -2$$

✓ Verify your solution(s):

$$2(4-1)^2 - 18 = 2(3)^2 - 18 = 2 \cdot 9 - 18 = 0 \checkmark$$

$$2(-2-1)^2 - 18 = 2(-3)^2 - 18 = 2 \cdot 9 - 18 = 0 \checkmark$$

14. $f(x) = 3x^2 - 24$

$$3x^2 - 24 = 0$$

$$3x^2 = 24$$

$$\sqrt{x^2} = \sqrt{8}$$

$$|x| = 2\sqrt{2}$$

$$x = \pm 2\sqrt{2}$$

✓ Verify your solution(s):

$$3(2\sqrt{2})^2 - 24 = 3(4 \cdot 2) - 24 = 24 - 24 = 0 \checkmark$$

$$3(-2\sqrt{2})^2 - 24 = 3(4 \cdot 2) - 24 = 24 - 24 = 0 \checkmark$$

15. The height of a ball in the air, h , at time t can be modeled by the equation $h(t) = -16(t-1)^2 + 32$. How long does it take for the ball to reach the ground? (round answers to the nearest hundredth)

$$-16(t-1)^2 + 32 = 0$$

$$-16(t-1)^2 = -32$$

$$\sqrt{(t-1)^2} = \sqrt{2}$$

$$|t-1| = \sqrt{2}$$

$$t-1 = \sqrt{2} \text{ or } t-1 = -\sqrt{2}$$

$$t = 1 + \sqrt{2} \text{ or } t = 1 - \sqrt{2}$$

$$t \approx 2.41 \text{ sec}$$

~~$t \approx -0.41$ extraneous~~

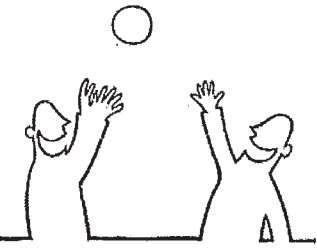

16. Big Bertha, a cannon used in WW1, could fire shells incredibly long distances. The page of a shell could be modeled by $y = -0.0196(x-25)^2 + 12$ where x was the horizontal distance traveled (in miles), and y was the height (in miles). How far could Big Bertha fire a shell? (round answers to the nearest mile)

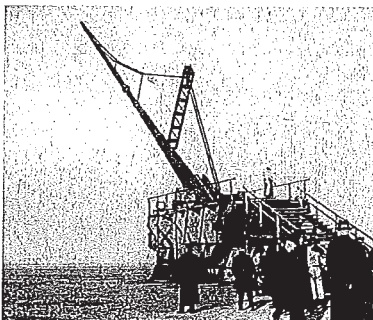

Big Bertha (Paris Gun), courtesy <http://www.militaryimages.net>

$$-0.0196(x-25)^2 + 12 = 0$$

$$-0.0196(x-25)^2 = -12$$

$$\sqrt{(x-25)^2} = \sqrt{612.245}$$

$$|x-25| = 24.74$$

$$x-25 = 24.74 \text{ or } x-25 = -24.74$$

$$x = 49.74 \text{ or } x = 0.26 \approx 0 \text{ miles}$$

~~$x = 0.26 \approx 0$ miles extraneous~~

Section 5.2F

5.2G Operations with Complex Expressions

1. Simplify each expression.

a) $i^2 = -1$

b) $i^4 = 1$

c) $i^{17} = i$

d) $-i^{10} = -(-1) = 1$

e) $i^{101} = i$

f) $i^{87} = -i$

g) $\sqrt{-25} = 5i$

h) $4\sqrt{-9} = 12i$

i) $5\sqrt{-28} = 10i\sqrt{7}$

j) $7\sqrt{-8} = 14i\sqrt{2}$

k) $-4\sqrt{-10} = -4i\sqrt{10}$

l) $5\sqrt{-100} = 50i$

2. Add or subtract each expression.

a) $(5-3i)+(4+7i) = 9+4i$

b) $(4-8i)+(9+2i) = 13-6i$

c) $(3-2i)-(5-4i) = -2+2i$

d) $6-(-5-\sqrt{-9}) = 11+3i$

e) $8i+(9-11i) = 9-3i$

f) $(7-\sqrt{-81})+(5-\sqrt{-100}) = 12-19i$

3. Simplify each expression.

a) $3i \cdot 2i = 6i^2 = 6(-1) = -6$

b) $-6i \cdot 2i = -12i^2 = -12(-1) = 12$

c) $4\sqrt{-6} \cdot 2\sqrt{3} = 8i\sqrt{6} \cdot 2\sqrt{3} = 16i\sqrt{18} = 24i\sqrt{2}$

d) $-3\sqrt{-20} \cdot 2\sqrt{5} = -6\sqrt{4 \cdot 5 \cdot 5} = -6 \cdot 2 \cdot 5 = -60i$

e) $8\sqrt{-2} \cdot 3\sqrt{2} = 24i\sqrt{2} \cdot \sqrt{2} = 48i$

f) $-2\sqrt{-6} \cdot 3\sqrt{-3} = -6i\sqrt{6} \cdot i\sqrt{3} = -6i^2\sqrt{18} = 6 \cdot 1 \cdot \sqrt{9 \cdot 2} = 18\sqrt{2}$

5.2G Operations with Complex Expressions

4. Kasem simplified the expression $\sqrt{-4} \cdot \sqrt{-9}$ using various methods.

1	WRONG	2	CORRECT	3	CORRECT
Line 1	$\sqrt{-4} \cdot \sqrt{-9}$	Line 1	$\sqrt{-4} \cdot \sqrt{-9}$	Line 1	$\sqrt{-4} \cdot \sqrt{-9}$
Line 2	$\sqrt{-4 \cdot -9}$	Line 2	$\sqrt{-1 \cdot 4} \cdot \sqrt{-1 \cdot 9}$	Line 2	$\sqrt{-1 \cdot 4} \cdot \sqrt{-1 \cdot 9}$
Line 3	$\sqrt{36}$	Line 3	$\sqrt{-1} \cdot \sqrt{4} \cdot \sqrt{-1} \cdot \sqrt{9}$	Line 3	$\sqrt{-1} \cdot \sqrt{4} \cdot \sqrt{-1} \cdot \sqrt{9}$
Line 4	6	Line 4	$\sqrt{-1} \cdot \sqrt{-1} \cdot \sqrt{4} \cdot \sqrt{9}$	Line 4	$i \cdot 2 \cdot i \cdot 3$
		Line 5	$i \cdot i \cdot \sqrt{4 \cdot 9}$	Line 5	$2 \cdot 3 \cdot i \cdot i$
		Line 6	$i^2 \cdot \sqrt{36}$	Line 6	$6 \cdot i^2$
		Line 7	$(-1)6$	Line 7	$6 \cdot (-1)$
		Line 8	-6	Line 8	-6

a) Other than simplifying to the different numeric values, identify 2 or more differences in the process shown used in methods 1 and 2.

- 1) In method 1, Kasem never used the definition of $i = \sqrt{-1}$ to rewrite either radical
- 2) Method 1 used the product property of radicals incorrectly;
 Only if a and b are BOTH nonnegative with an even index, is $\sqrt{a} \sqrt{b} = \sqrt{ab}$
 Method 2 used the product property of radicals correctly.

b) Although the methods have created different numeric values when simplifying, identify 2 or more similarities in the process shown in methods 1 and 2.

- 1) Both methods combined $\sqrt{4 \cdot 9} = \sqrt{36}$ instead of simplifying each separately.
- 2) Both methods used fact that $\sqrt{36} = 6$

c) Although the methods have created the same numeric value, identify 2 or more differences in the process shown through methods 2 and 3.

- 1) From line 3 to line 4, multiplication was done in a different order by commutative property for multiplication.
- 2) Method 3 simplified the radicals $\sqrt{4}$ and $\sqrt{9}$; method 2 multiplied them together.

d) Other than simplifying to the same numeric values, identify 2 or more similarities in the process shown in methods 2 and 3.

- 1) Both used definition of $i = \sqrt{-1}$ wherever there was a $\sqrt{-1}$.
- 2) Both used fact that $i^2 = -1$

5. Simplify each expression.

a) $\sqrt{-6} \cdot \sqrt{-2}$
 $i\sqrt{6} \cdot i\sqrt{2}$
 $i^2 \sqrt{12}$
 $-1 \sqrt{4 \cdot 3}$
 $-1 \cdot 2 \sqrt{3} = -2\sqrt{3}$

b) $3\sqrt{-5} \cdot 2\sqrt{-8}$
 $6i\sqrt{5} \cdot i\sqrt{4 \cdot 2}$
 $6i^2 \sqrt{5} \cdot 2 \cdot \sqrt{2}$
 $12(-1)\sqrt{10} = -12\sqrt{10}$

c) $-3\sqrt{-2} \cdot 7\sqrt{-9}$
 $-21i\sqrt{2} \cdot 3i$
 $-63i^2 \sqrt{2}$
 $-63(-1)\sqrt{2} = 63\sqrt{2}$

5.2G Operations with Complex Expressions

6. Simplify each expression.

$$\begin{array}{l} \text{a) } 5(1-3i) \\ \hline 5-15i \end{array}$$

$$\begin{array}{l} \text{b) } 3(3+i) \\ \hline 9+3i \end{array}$$

$$\begin{array}{l} \text{c) } 3(2-4\sqrt{-25}) \\ 6-12\sqrt{-25} \\ 6-12\sqrt{-1\cdot 25} \\ 6-12i\cdot 5 \\ \hline 6-60i \end{array}$$

$$\begin{array}{l} \text{d) } -3i(2+4i) \\ -6i-12i^2 \\ -6i-12(-1) \\ -6i+12 \\ \hline 12-6i \end{array}$$

$$\begin{array}{l} \text{e) } -5i(-8+2i) \\ 40i-10(i^2) \\ 40i-10(-1) \\ \hline 10+40i \end{array}$$

$$\begin{array}{l} \text{f) } \sqrt{-10}(2-\sqrt{-2}) \\ i\sqrt{10}(2-i\sqrt{2}) \\ 2i\sqrt{10}-i^2\sqrt{20} \\ 2i\sqrt{10}-(-1)2\sqrt{5} \\ 2i\sqrt{10}+2\sqrt{5} \\ \hline 2\sqrt{5}+2i\sqrt{10} \end{array}$$

7. Simplify each expression.

$$\begin{array}{l} \text{a) } (3+5i)(3+5i) \\ 9+30i+25i^2 \\ 9+30i-25 \\ \hline -16+30i \end{array}$$

$$\begin{array}{l} \text{b) } 3(4-2i)^2 \\ 3(16-16i+4i^2) \\ 3(16-16i-4) \\ 3(12-16i) \\ \hline 36-48i \end{array}$$

$$\begin{array}{l} \text{c) } (5-3i\sqrt{2})^2 \\ 25-30i\sqrt{2}+9\cdot 2i^2 \\ 25-30i\sqrt{2}-18 \\ \hline 7-30i\sqrt{2} \end{array}$$

8. Simplify each expression.

$$\begin{array}{l} \text{a) } 4(1+3i\sqrt{2})(1+3i\sqrt{2}) \\ 4(1+6i\sqrt{2}+9i^2\cdot 2) \\ 4(1+6i\sqrt{2}-18) \\ 4(-17+6i\sqrt{2}) \\ \hline -68+24i\sqrt{2} \end{array}$$

$$\begin{array}{l} \text{b) } 3(4-2i\sqrt{7})^2 \\ 3(16-16i\sqrt{7}+4i^2\cdot 7) \\ 3(16-16i\sqrt{7}-28) \\ 3(-12-16i\sqrt{7}) \\ \hline -36-48i\sqrt{7} \end{array}$$

$$\begin{array}{l} \text{c) } 3(2-i\sqrt{11})^2-5(2-i\sqrt{11})+7 \\ 3(4-4i\sqrt{11}+i^2\cdot 11) \\ 3(4-4i\sqrt{11}-11) \\ 3(-7-4i\sqrt{11}) \\ -21-12i\sqrt{11} \\ -10+5i\sqrt{11}+7 \\ \hline -24-7i\sqrt{11} \end{array}$$

5.2G Operations with Complex Expressions

9. Verify that the given answer (value of x) is a solution to the equation.

a) $-2x^2 + 6 = 56; x = 5i$
 $-2(5i)^2 + 6 = 56$
 $-2(25i^2) = 50$
 $50 + 6 = 56 \checkmark$

b) $x^2 - 8x + 30 = 5; x = (4 + 3i)$
 $(4 + 3i)^2 - 8(4 + 3i) + 30 = 5$
 $16 + 24i + 9i^2 - 32 - 24i + 30 = 5$
 $16 + 24i - 9 - 32 - 24i + 30 = 5$
 $5 = 5 \checkmark$

c) $x^2 - 2x + 48 = 2; x = (1 - 3i\sqrt{5})$
 $(1 - 3i\sqrt{5})^2 - 2(1 - 3i\sqrt{5}) + 48 = 2$
 $1 - 6i\sqrt{5} + 9i^2 \cdot 5 - 2 + 6i\sqrt{5} + 48 = 2$
 $1 - 6i\sqrt{5} - 45 - 2 + 6i\sqrt{5} + 48 = 2$
 $-46 + 48 = 2$
 $2 = 2 \checkmark$

10. Simplify each expression (no decimal values allowed).

a) $\frac{6+8i}{2}$
 $3 + 4i$

b) $\frac{6+10i\sqrt{2}}{2}$
 $3 + 5i\sqrt{2}$

c) $\frac{-15-21i\sqrt{6}}{3}$
 $-5 - 7i\sqrt{6}$

d) $\frac{-30 + \sqrt{-75}}{5}$
 $\frac{-30 + 5i\sqrt{3}}{5}$
 $-6 + i\sqrt{3}$

11. Verify that the given answer (value of x) is a solution to the equation.

$2x^2 - 6x + 8 = 3; x = \frac{3+i}{2}$
 $2\left(\frac{3+i}{2}\right)^2 - 6\left(\frac{3+i}{2}\right) + 8 = 3$
 $2\left(\frac{9+6i+i^2}{4}\right) - 3(3+i) + 8$
 $2\left(\frac{8+6i}{4}\right) - 9 - 3i + 8$
 $\frac{8+6i}{2} - 9 - 3i + 8$
 $4 + 3i - 9 - 3i + 8$
 $3 = 3 \checkmark$

Section 5.2G

5.2H Solve Quadratic Equations Using Square Roots to Find Real or Complex Solutions

#1 – 6: Simplify the following radicals.

1. $\sqrt{-9}$
 $\boxed{3i}$

2. $7\sqrt{-50}$
 $7\sqrt{-1 \cdot 25 \cdot 2}$
 $7 \cdot 5\sqrt{2}$
 $\boxed{35i\sqrt{2}}$

3. $2\sqrt{-3}$
 $\boxed{2i\sqrt{3}}$

4. $3\sqrt{-100}$
 $\boxed{30i}$

5. $11\sqrt{-18}$
 $11\sqrt{-1 \cdot 9 \cdot 2}$
 $\boxed{33i\sqrt{2}}$

6. $\sqrt{-121}$
 $\boxed{11i}$

7. What is the value of i^2 ?
 $\boxed{-1}$

#8 – 13: Simplify the following complex expressions.

8. $(3i)^2$
 $9i^2$
 $\boxed{-9}$

9. $(-5i)^2$
 $25i^2$
 $\boxed{-25}$

10. $(-i)^2$
 $i^2 =$
 $\boxed{-1}$

11. $(3-5i)^2$
 $9 - 30i + 25i^2$
 $9 - 30i - 25$
 $\boxed{-16 - 30i}$

12. $2(3+4i)^2$
 $2(9 + 24i + 16i^2)$
 $2(-7 + 24i)$
 $\boxed{-14 + 48i}$

13. $(-2-7i)^2 + 5$
 $4 + 28i + 49i^2 + 5$
 $4 + 28i - 49 + 5$
 $\boxed{-40 + 28i}$

#14 – 17: Verify that each of the following values are solutions to the given equation. Show all of your work.

14. $-2x^2 + 3 = 21$; $x = 3i, x = -3i$

$-2(3i)^2 + 3 = 21$
 $-2(9i^2)$
 $-2(9)(-1)$
 $18 + 3 = 21 \checkmark$

$-2(-3i)^2 + 3 = 21$
 $-2(9i^2)$
 $-18i^2$
 $18 + 3 = 21 \checkmark$

15. $(x-5)^2 - 1 = -17$; $x = 5+4i, x = 5-4i$

$((5+4i)-5)^2 - 1 = -17$
 $(4i)^2$
 $16i^2$
 $-16 - 1 = -17 \checkmark$

$((5-4i)-5)^2 - 1 = -17$
 $(-4i)^2 - 1$
 $16i^2$
 $-16 - 1 = -17 \checkmark$

5.2H Solve Quadratic Equations Using Square Roots to Find Real or Complex Solutions

#14 – 17 (continued): Verify that each of the following values are solutions to the given equation. Show all of your work.

16. $x^2 + 11 = 7$; $x = 2i, x = -2i$

$$(2i)^2 + 11 = 7$$

$$4i^2 + 11$$

$$4(-1) + 11 = 7 \checkmark$$

$$(-2i)^2 + 11 = 7$$

$$4i^2$$

$$-4 + 11 = 7 \checkmark$$

17. $(x+2)^2 = -25$; $x = -2+5i, x = -2-5i$

$$((-2+5i)+2)^2 = -25$$

$$(5i)^2$$

$$25i^2$$

$$25(-1) = -25 \checkmark$$

$$((-2-5i)+2)^2 = -25$$

$$(-5i)^2$$

$$25i^2$$

$$25(-1) = -25 \checkmark$$

#18 – 21: Solve each equation for real or complex solutions. Verify your solutions.

18. $x^2 + 3 = 51$

$$\sqrt{x^2} = \sqrt{48}$$

$$|x| = \sqrt{16 \cdot 3}$$

$$x = \pm 4\sqrt{3}$$

19. $\sqrt{(x-1)^2} = \sqrt{-24}$

$$|x-1| = \sqrt{-1 \cdot 4 \cdot 6}$$

$$x-1 = \pm 2i\sqrt{6}$$

$$x = 1 + 2i\sqrt{6}, x = 1 - 2i\sqrt{6}$$

✓ Verify your solution(s):

$$(4\sqrt{3})^2 + 3 = 51$$

$$16 \cdot 3 + 3 = 51 \checkmark$$

$$(-4\sqrt{3})^2 + 3 = 51 \checkmark$$

$$16 \cdot 3 + 3 = 51 \checkmark$$

✓ Verify your solution(s):

$$((1 + 2i\sqrt{6}) - 1)^2 = -24$$

$$(2i\sqrt{6})^2$$

$$4i^2 \cdot 6$$

$$24(-1) = -24 \checkmark$$

$$((1 - 2i\sqrt{6}) - 1)^2 = -24$$

$$(-2i\sqrt{6})^2$$

$$4i^2 \cdot 6$$

$$24(-1) = -24 \checkmark$$

5.2H Solve Quadratic Equations Using Square Roots to Find Real or Complex Solutions

#18 – 21 (continued): Solve each equation for real or complex solutions. Verify your solutions.

20. $3x^2 - 27 = 0$

$$3x^2 = 27$$

$$\sqrt{x^2} = \sqrt{9}$$

$$|x| = 3$$

$x = 3 \text{ or } x = -3$

✓ Verify your solution(s):

$$3(3)^2 - 27 = 0$$

$$3 \cdot 9 - 27 = 0 \checkmark$$

$$3(-3)^2 - 27 = 0$$

$$3 \cdot 9 - 27 = 0 \checkmark$$

21. $5(x+1)^2 - 3 = -48$

$$5(x+1)^2 = -45$$

$$\sqrt{(x+1)^2} = \sqrt{-9}$$

$$|x+1| = 3i$$

$$x+1 = \pm 3i$$

$x = -1 + 3i, x = -1 - 3i$

✓ Verify your solution(s):

$$5((-1+3i)+1)^2 - 3 = -48$$

$$5(3i)^2$$

$$5 \cdot 9i^2$$

$$45i^2$$

$$-45 - 3 = -48 \checkmark$$

$$5((-1-3i)+1)^2 - 3 = -48$$

$$5(-3i)^2$$

$$5 \cdot 9i^2$$

$$45i^2$$

$$-45 - 3 = -48 \checkmark$$

22. The height, h , of a water balloon (in feet) at time t (in seconds) is given by the equation

$h(t) = -16(t - 0.45)^2 + 32$. If a student throws the balloon and it lands on the ground, how long is the balloon in the air? Verify your solution(s).

$$0 = -16(t - 0.45)^2 + 32$$

$$-32 = -16(t - 0.45)^2$$

$$\sqrt{2} = \sqrt{(t - 0.45)^2}$$

$$\pm \sqrt{2} = |t - 0.45|$$

* $t = 0.45 + \sqrt{2}$ $t = 0.45 - \sqrt{2} \approx -0.96$ * Using $t \approx 1.8642$ to 4 decimal places yields $0 = 0 \checkmark$

extraneous

#23 – 26: Find the real and/or complex roots of each function. Verify your solutions!

23. $f(x) = x^2 - 125$

$$x^2 - 125 = 0$$

$$\sqrt{x^2} = \sqrt{125}$$

$$|x| = \sqrt{25 \cdot 5}$$

$x = 5\sqrt{5} \text{ or } x = -5\sqrt{5}$

✓ Verify your solution(s):

$$(5\sqrt{5})^2 - 125 = 0$$

$$25 \cdot 5 - 125 = 0 \checkmark$$

$$(-5\sqrt{5})^2 - 125 = 0$$

$$25 \cdot 5 - 125 = 0 \checkmark$$

24. $f(x) = (x+7)^2$

$$\sqrt{(x+7)^2} = \sqrt{0}$$

$$|x+7| = 0$$

$$x+7 = 0$$

$x = -7$

✓ Verify your solution(s):

$$(-7+7)^2 = 0$$

$$0^2 = 0 \checkmark$$

5.2H Solve Quadratic Equations Using Square Roots to Find Real or Complex Solutions

#23 – 26 (continued): Find the real and/or complex roots of each function. Verify your solutions!

25. $f(x) = -2(x-2)^2 - 18$

$$\begin{aligned} -2(x-2)^2 - 18 &= 0 \\ -2(x-2)^2 &= 18 \\ \sqrt{(x-2)^2} &= \sqrt{-9} \\ |x-2| &= 3i \\ x-2 &= \pm 3i \\ \boxed{x = 2+3i, x = 2-3i} \end{aligned}$$

✓ Verify your solution(s):

$$\begin{aligned} -2(2+3i-2)^2 - 18 &= 0 & -2(2-3i-2)^2 - 18 &= 0 \\ -2(3i)^2 & & -2(-3i)^2 & \\ -2(9i^2) & & -2(9i^2) & \\ -2(-9) - 18 &= 0 \checkmark & -2(-9) - 18 &= 0 \checkmark \end{aligned}$$

26. $f(x) = 4x^2 + 24$

$$\begin{aligned} 4x^2 + 24 &= 0 \\ 4x^2 &= -24 \\ \sqrt{x^2} &= \sqrt{-6} \\ |x| &= i\sqrt{6} \\ \boxed{x = i\sqrt{6} \text{ or } -i\sqrt{6}} \end{aligned}$$

✓ Verify your solution(s):

$$\begin{aligned} 4(i\sqrt{6})^2 + 24 &= 0 & 4(-i\sqrt{6})^2 + 24 &= 0 \\ 4 \cdot i^2 \cdot 6 & & 4(i^2 \cdot 6) & \\ -24 + 24 &= 0 \checkmark & -24 + 24 &= 0 \checkmark \end{aligned}$$

27. The area of a square can be found using the formula $A = s^2$, where "A" is the area and "s" is the length of one side. If the area of a square is 50 square inches, what is the length of one side? Round your answer to the nearest thousandth and verify your solution(s).

$$\begin{aligned} A &= s^2 \\ \sqrt{50} &= \sqrt{s^2} \\ \sqrt{50} &= |s| \\ \pm \sqrt{50} &= s \\ \text{But length is positive} \\ \boxed{s \approx 7.071 \text{ in}} \end{aligned}$$

$$\begin{aligned} (7.071)^2 &= 50 \\ 49.999 &\approx 50 \checkmark \end{aligned}$$

28. The function $f(x) = x^2 + 4$ has no x -intercepts, as shown in the graph to the right. Use algebra to show that no real roots exist for this function.

$$\begin{aligned} x^2 + 4 &= 0 \\ \sqrt{x^2} &= \sqrt{-4} \end{aligned}$$

$$|x| = 2i$$

$$\boxed{x = 2i \text{ or } x = -2i}$$

Both roots are imaginary

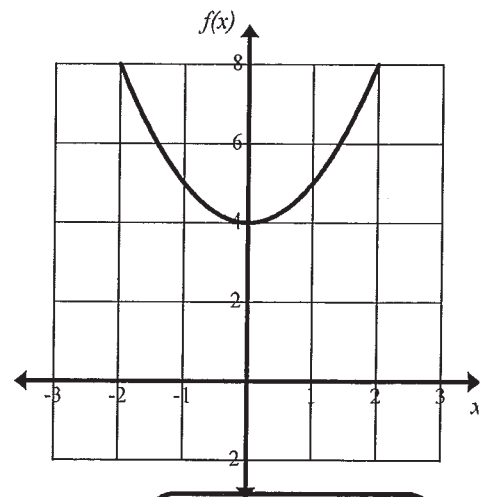

Section 5.2H

5.2I Solving Quadratic Equations by Completing the Square to Find Rational Solutions

#1 - 3: Solve using square roots.

1. $\sqrt{(x-2)^2} = \sqrt{25}$
 $|x-2| = 5$
 $x-2 = 5$ or $x-2 = -5$
 $x = 7$ or $x = -3$

2. $\sqrt{(x+4)^2} = \sqrt{16}$
 $|x+4| = 4$
 $x+4 = 4$ or $x+4 = -4$
 $x = 0$ or $x = -8$

3. $\sqrt{121} = \sqrt{(x-7)^2}$
 $|x-7| = 11$
 $x-7 = 11$ or $x-7 = -11$
 $x = 18$ or $x = -4$

4. Find and explain the error made when solving the following equation. $x^2 + 10x = 24$

Line 1	$x^2 + 10x = 24$
Line 2	$x^2 + 10x + 25 = 24$
Line 3	$(x+5)^2 = 24$
Line 4	$\sqrt{(x+5)^2} = \sqrt{24}$
Line 5	$ x+5 = \sqrt{24}$
Line 6	$x+5 = \pm 2\sqrt{6}$
Line 7	$x+5 = 2\sqrt{6}$ and $x+5 = -2\sqrt{6}$
Line 8	$x = -5 + 2\sqrt{6}$ $x = -5 - 2\sqrt{6}$
Line 9	$x = -5 \pm 2\sqrt{6}$

* Forgot to add 25 to both sides of the equation.

#5 - 6: Fill in the missing value to create a perfect square trinomial. Then solve by Completing the Square.

5. $40 + \frac{9}{49} = x^2 + 6x + \frac{9}{49}$
 $\sqrt{49} = \sqrt{(x+3)^2}$
 $7 = |x+3|$
 $x+3 = 7$ or $x+3 = -7$
 $x = 4$ or $x = -10$

6. $x^2 - 18x + 81 = 88 + \frac{81}{9}$
 $\sqrt{(x-9)^2} = \sqrt{169}$
 $|x-9| = 13$
 $x-9 = 13$ or $x-9 = -13$
 $x = 22$ or $x = -4$

#7 - 10: Solve by Completing the Square. Then verify your solutions.

7. $29 = x^2 + 28x + 196$
 $\sqrt{225} = \sqrt{(x+14)^2}$
 $15 = |x+14|$
 $x+14 = 15$ or $x+14 = -15$
 $x = 1$ or $x = -29$

Checks:
 $(1)^2 + 28(1) = 29$
 $(-29)^2 + 28(-29) = 841 - 812 = 29$

8. $x^2 - 10x - 56 = 0$
 $x^2 - 10x + 25 = 56 + 25$
 $\sqrt{(x-5)^2} = \sqrt{81}$
 $x-5 = 9$ or $x-5 = -9$
 $x = 14$ or $x = -4$

Checks:
 $(14)^2 - 10(14) - 56 = 196 - 140 - 56 = 0$
 $(-4)^2 - 10(-4) - 56 = 16 + 40 - 56 = 0$

9. $-23 = x^2 - 12x + 13$
 $-36 = x^2 - 12x + 36$
 $\sqrt{0} = \sqrt{(x-6)^2}$
 $|x-6| = 0$
 $x = 6$

Ch:
 $(6)^2 - 12(6) + 13 = 36 - 72 + 13 = -23$

10. $x^2 + 7 = 30x - 74$
 $x^2 - 30x = -81$
 $x^2 - 30x + 225 = -81 + 225$
 $\sqrt{(x-15)^2} = \sqrt{144}$
 $|x-15| = 12$
 $x-15 = 12$ or $x-15 = -12$
 $x = 27$ or $x = 3$

Checks:
 $(27)^2 + 7 = 30(27) - 74$
 $736 = 736$
 $(3)^2 + 7 = 30(3) - 74$
 $16 = 16$

5.2I Solving Quadratic Equations by Completing the Square to Find Rational Solutions

11. The product of two consecutive positive even integers is 528. What are the numbers?

(Solve by Completing the Square)

Let n = smaller of 2 pos. ints
 $n+2$ = next consecutive pos. int.

$$n(n+2) = 528$$

$$n^2 + 2n + 1 = 528 + 1$$

$$\sqrt{(n+1)^2} = \sqrt{529}$$

$$|n+1| = 23$$

$$n+1 = 23 \text{ or } n+1 = -23$$

$$\begin{matrix} 1 & - \\ -1 & - \end{matrix}$$

$$n = -24$$

extraneous

$$\boxed{n = 22}$$

$$\boxed{n+2 = 24}$$

The 2 consecutive positive even integers are 22 & 24.

Check

$$22(24) = 528 \checkmark$$

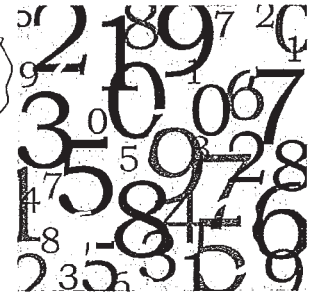

12. A square garden is altered so that one dimension is decreased by 3 yards, while the other dimension is increased by 5 yards. The area of the resulting rectangle is 20 square yards. Find the length of each side of the original garden and its area. (Solve by Completing the Square)

x = length of side of square

$$(x-3)(x+5) = 20$$

$$x^2 + 2x - 15 = 20$$

$$x^2 + 2x + 1 = 35 + 1$$

$$\sqrt{(x+1)^2} = \sqrt{36}$$

$$|x+1| = 6$$

$$x+1 = 6 \text{ or } x+1 = -6$$

extraneous

$$\boxed{x = 5 \text{ yds}}$$

$$\boxed{\text{Area} = 5^2 = 25 \text{ yd}^2}$$

Check

$$(5-3)(5+5) = 20$$

$$2(10) = 20 \checkmark$$

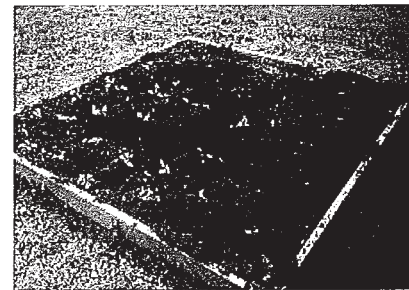

13. A foul ball leaves the end of a baseball bat and travels according to the formula $h(t) = -16t^2 + 64t$ where h is the height of the ball in feet and t is the time in seconds. How long will it take for the ball to reach a height of 64 feet in the air? (Solve by Completing the Square)

$$\frac{-16t^2 + 64t}{-16} = \frac{64}{-16}$$

$$t^2 - 4t = -4$$

$$t^2 - 4t + 4 = -4 + 4$$

$$\sqrt{(t-2)^2} = \sqrt{0}$$

$$|t-2| = 0$$

$$t-2 = 0$$

$$\boxed{t = 2 \text{ secs}}$$

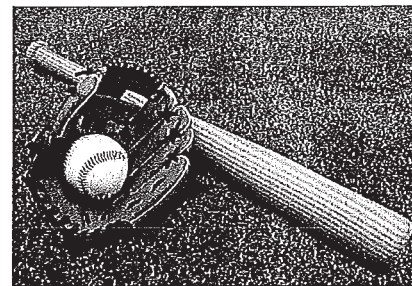

Section 5.2I

5.2J Solving Quadratic Equations by Completing the Square to Find Real Solutions

#1 - 3: Solve using square roots.

1. $\sqrt{(x+7)^2} = \sqrt{15}$
 $|x+7| = \sqrt{15}$
 $x+7 = 15$ or $x+7 = -15$
 $x = -7 + \sqrt{15}$ $x = -7 - \sqrt{15}$
 $x = -7 \pm \sqrt{15}$

2. $\sqrt{(x-9)^2} = \sqrt{12}$
 $|x-9| = 2\sqrt{3}$
 $x-9 = \pm 2\sqrt{3}$
 $x = 9 \pm 2\sqrt{3}$

3. $\sqrt{32} = \sqrt{(x-5)^2}$
 $|x-5| = 4\sqrt{2}$
 $x-5 = \pm 4\sqrt{2}$
 $x = 5 \pm 4\sqrt{2}$

#4 - 5: Fill in the missing value to create a perfect square trinomial. Then solve by Completing the Square.

4. $7 + \frac{25}{4} = x^2 + 5x + \frac{25}{4}$
 $\frac{28}{4} + \frac{25}{4} = (x + \frac{5}{2})^2$
 $\sqrt{\frac{53}{4}} = \sqrt{(x + \frac{5}{2})^2}$
 $\frac{\sqrt{53}}{2} = |x + \frac{5}{2}|$
 $\pm \frac{\sqrt{53}}{2} = x + \frac{5}{2}$
 $x = \frac{-5 \pm \sqrt{53}}{2}$

5. $x^2 - 7x + \frac{49}{4} = -3 + \frac{49}{4}$
 $(x - \frac{7}{2})^2 = \frac{-12}{4} + \frac{49}{4}$
 $\sqrt{(x - \frac{7}{2})^2} = \sqrt{\frac{37}{4}}$
 $|x - \frac{7}{2}| = \frac{\sqrt{37}}{2}$
 $x - \frac{7}{2} = \pm \frac{\sqrt{37}}{2}$
 $x = \frac{7 \pm \sqrt{37}}{2}$

#6 - 9: Solve by Completing the Square. Then verify your solutions. (see next page)

6. $-88 = x^2 + 28x + 196$
 $\sqrt{108} = \sqrt{(x+14)^2}$
 $6\sqrt{3} = |x+14|$
 $\pm 6\sqrt{3} = x+14$
 $x = -14 \pm 6\sqrt{3}$

7. $2x^2 - 7x - 13 = -10$
 $2x^2 - 7x = 3$
 $x^2 - \frac{7}{2}x + \frac{49}{16} = \frac{3}{2} + \frac{49}{16}$
 $\sqrt{(x - \frac{7}{4})^2} = \sqrt{\frac{73}{16}}$
 $|x - \frac{7}{4}| = \frac{\sqrt{73}}{4}$
 $x - \frac{7}{4} = \pm \frac{\sqrt{73}}{4}$
 $x = \frac{7 \pm \sqrt{73}}{4}$

8. $8 = 4x^2 + 4x - 13$
 $21 = 4x^2 + 4x$
 $\frac{21}{4} = x^2 + x$
 $\frac{21}{4} + \frac{1}{4} = x^2 + x + \frac{1}{4}$
 $\sqrt{\frac{22}{4}} = \sqrt{(x + \frac{1}{2})^2}$
 $\frac{\sqrt{22}}{2} = |x + \frac{1}{2}|$
 $\pm \frac{\sqrt{22}}{2} = x + \frac{1}{2}$
 $x = \frac{-1 \pm \sqrt{22}}{2}$

9. $9x^2 - 1 = 6x$
 $9x^2 - 6x = 1$
 $x^2 - \frac{2}{3}x = \frac{1}{9}$
 $x^2 - \frac{2}{3}x + \frac{1}{9} = \frac{1}{9} + \frac{1}{9}$
 $\sqrt{(x - \frac{1}{3})^2} = \sqrt{\frac{2}{9}}$
 $|x - \frac{1}{3}| = \frac{\sqrt{2}}{3}$
 $x - \frac{1}{3} = \pm \frac{\sqrt{2}}{3}$
 $x = \frac{1 \pm \sqrt{2}}{3}$

10. For which values of y, given $y = x^2 + bx + (\frac{b}{2})^2$, will you find 2 real solutions? 1 real solution?

when $y > 0$, there will be 2 real solutions.
 when $y = 0$, there will be 1 real solution.

P-35 Checks

#6 $-88 = x^2 + 28x$ Verifying $x = 74 \pm 6\sqrt{3}$

$$\begin{aligned} -88 &= (-14 + 6\sqrt{3})^2 + 28(-14 + 6\sqrt{3}) \\ &= (196 - 168\sqrt{3} + 108) \\ &= 304 - 168\sqrt{3} - 392 + 168\sqrt{3} \\ -88 &= -88 \checkmark \end{aligned}$$

Also

$$\begin{aligned} -88 &= (-14 - 6\sqrt{3})^2 + 28(-14 - 6\sqrt{3}) \\ &= 196 + 168\sqrt{3} + 108 \\ &= 304 + 168\sqrt{3} - 392 - 168\sqrt{3} \\ -88 &= -88 \checkmark \end{aligned}$$

#7 $2x^2 - 7x - 13 = 70$ Verifying $x = \frac{7 \pm \sqrt{73}}{4}$

$$2\left(\frac{7 + \sqrt{73}}{4}\right)^2 - 7\left(\frac{7 + \sqrt{73}}{4}\right) - 13 = 70$$

$$2\left(\frac{49 + 14\sqrt{73} + 73}{16}\right)$$

$$\frac{122 + 14\sqrt{73}}{8}$$

$$\frac{61 + 7\sqrt{73}}{4}$$

$$- \frac{49 + 7\sqrt{73}}{4}$$

$$\frac{12}{4} - 13$$

$$3 - 13 = -10 \checkmark$$

Also

$$2\left(\frac{7 - \sqrt{73}}{4}\right)^2 - 7\left(\frac{7 - \sqrt{73}}{4}\right) - 13 = 70$$

$$2\left(\frac{49 - 14\sqrt{73} + 73}{16}\right)$$

$$\frac{122 - 14\sqrt{73}}{8}$$

$$\frac{61 - 7\sqrt{73}}{4}$$

$$- \frac{49 - 7\sqrt{73}}{4}$$

$$\frac{12}{4} - 13$$

$$3 - 13 = -10 \checkmark$$

P-35 checks

(#8) $4x^2 + 4x - 13 = 8$ Verifying $x = \frac{-1 \pm \sqrt{22}}{2}$

$$4\left(\frac{-1+\sqrt{22}}{2}\right)^2 + 4\left(\frac{-1+\sqrt{22}}{2}\right) - 13 = 8$$
$$4\left(\frac{1-2\sqrt{22}+22}{4}\right) + 2(-1+\sqrt{22}) - 13 = 8$$
$$23 - 2\sqrt{22} - 2 + 2\sqrt{22} - 13 = 8 \checkmark$$
$$21 - 13 = 8 \checkmark$$

Also

$$4\left(\frac{-1-\sqrt{22}}{2}\right)^2 + 4\left(\frac{-1-\sqrt{22}}{2}\right) - 13 = 8$$
$$4\left(\frac{1+2\sqrt{22}+22}{4}\right) + 2(-1-\sqrt{22}) - 13 = 8$$
$$23 + 2\sqrt{22} - 2 - 2\sqrt{22} - 13 = 8$$
$$21 - 13 = 8 \checkmark$$

(#9) $9x^2 - 1 = 6x$ Verifying $x = \frac{1 \pm \sqrt{2}}{3}$

$$9\left(\frac{1+\sqrt{2}}{3}\right)^2 - 1 = 6\left(\frac{1+\sqrt{2}}{3}\right)$$
$$9\left(\frac{1+2\sqrt{2}+2}{9}\right) - 1 = 2(1+\sqrt{2})$$
$$3 + 2\sqrt{2} - 1 = 2 + 2\sqrt{2} \checkmark$$

Also

$$9\left(\frac{1-\sqrt{2}}{3}\right)^2 - 1 = 6\left(\frac{1-\sqrt{2}}{3}\right)$$
$$9\left(\frac{1-2\sqrt{2}+2}{9}\right) - 1 = 2(1-\sqrt{2})$$
$$3 - 2\sqrt{2} - 1 = 2 - 2\sqrt{2} \checkmark$$

5.2J Solving Quadratic Equations by Completing the Square to Find Real Solutions

11. A pool measuring 12 meters by 16 meters is to have a sidewalk installed all around it, increasing the total area to 285 square meters. What will be the width of the sidewalk? (Solve by Completing the Square and round your solution to the nearest hundredth.)

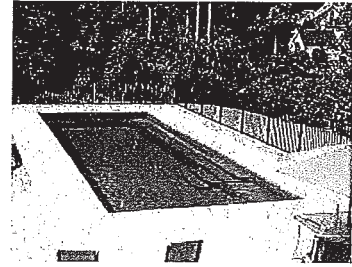

$$\begin{aligned} \text{width} &= x \\ (12+2x)(16+2x) &= 285 \\ 192 + 24x + 32x + 4x^2 &= 285 \\ 4x^2 + 56x &= 93 \end{aligned}$$

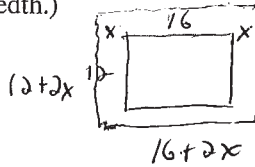

$$\begin{aligned} \frac{4x^2 + 56x}{4} &= \frac{93}{4} \\ x^2 + 14x + 49 &= \frac{93}{4} + \frac{49}{4} \\ \sqrt{(x+7)^2} &= \sqrt{72.25} \\ |x+7| &= 8.5 \end{aligned}$$

$$x+7 = 8.5 \quad \text{or} \quad x+7 = -8.5$$

$$x = 1.5$$

12. The height h in feet of an arrow shot upward from the top of a 96-foot tall tower when time $t=0$ is given by $h(t) = -16t^2 + 80t + 96$. How long will it take the arrow to strike the ground? (Solve by Completing the Square and round your solution to the nearest hundredth.)

$$\begin{aligned} -16t^2 + 80t + 96 &= 0 \\ t^2 - 5t - 6 &= 0 \\ t^2 - 5t + \frac{25}{4} &= 6 + \frac{25}{4} \\ \sqrt{\left(t - \frac{5}{2}\right)^2} &= \sqrt{\frac{49}{4}} \end{aligned}$$

$$\left|t - \frac{5}{2}\right| = \frac{7}{2}$$

$$t - \frac{5}{2} = \frac{7}{2} \quad \text{or} \quad t - \frac{5}{2} = -\frac{7}{2}$$

$$t = 6 \text{ seconds}$$



13. The height h in feet of a bottle rocket launched from a deck 8 feet above the ground is given by $h(t) = -16t^2 + 240t + 8$, where t is the time in seconds.

- a) What is the height after 2 seconds?

$$h(2) = -16(2)^2 + 240(2) + 8$$

$$h(2) = 424 \text{ ft}$$

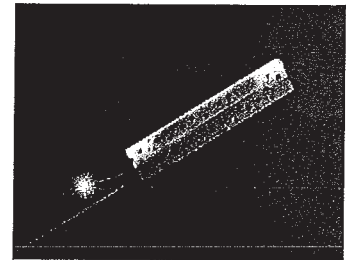

- b) At what times will the rocket be at a height of 400 feet? (Solve by Completing the Square and round your solution to the nearest hundredth.)

$$\begin{aligned} -16t^2 + 240t + 8 &= 400 \\ -16t^2 + 240t &= 392 \\ \frac{-16t^2 + 240t}{-16} &= \frac{392}{-16} \end{aligned}$$

$$\sqrt{\left(t - \frac{15}{2}\right)^2} = \sqrt{31.75}$$

$$\left|t - \frac{15}{2}\right| = 5.6347$$

$$t - 7.5 = 5.6347 \quad \text{or} \quad t - 7.5 = -5.6347$$

$$t \approx 13.13 \text{ secs OR } t = 1.87 \text{ secs}$$

Both solutions are correct

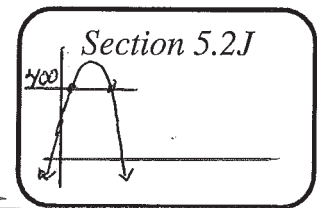

5.2K Solving Quadratic Equations by Completing the Square to Find Real or Complex Solutions

#1 – 3: Solve using square roots.

$$1. \sqrt{(x-5)^2} = \sqrt{-144}$$

$$|x-5| = 12i$$

$$x = 5 \pm 12i$$

$$2. \sqrt{(x-7)^2} = \sqrt{-24}$$

$$|x-7| = 2i\sqrt{6}$$

$$x = 7 \pm 2i\sqrt{6}$$

$$3. \sqrt{-128} = \sqrt{(x+13)^2}$$

$$8i\sqrt{2} = |x+13|$$

$$x = -13 \pm 8i\sqrt{2}$$

#4 – 5: Fill in the missing value to create a perfect square trinomial. Then solve by Completing the Square.

$$4. -40 + \underline{36} = x^2 + 12x + \underline{36}$$

$$\sqrt{-4} = \sqrt{(x+6)^2}$$

$$2i = |x+6|$$

$$x = -6 \pm 2i$$

$$5. x^2 - 24x + \underline{144} = -216 + \underline{144}$$

$$\sqrt{(x-12)^2} = \sqrt{-72}$$

$$|x-12| = 6i\sqrt{2}$$

$$x = 12 \pm 6i\sqrt{2}$$

#6 – 9: Solve by Completing the Square. Then verify your solutions. (see next page)

$$6. 4x = x^2 + 5x + 4$$

$$\frac{1}{4}x - 4 = x^2 + x + \frac{1}{4}$$

$$\sqrt{\frac{-15}{4}} = \sqrt{(x+\frac{1}{2})^2}$$

$$\frac{i\sqrt{15}}{2} = |x+\frac{1}{2}|$$

$$x = \frac{-1 \pm i\sqrt{15}}{2}$$

$$7. x^2 - 4x + 20 = 0$$

$$x^2 - 4x + 4 = -20 + 4$$

$$\sqrt{(x-2)^2} = \sqrt{-16}$$

$$|x-2| = 4i$$

$$x = 2 \pm 4i$$

$$8. 6x + 23 = 10x^2 + 26$$

$$10x^2 - 6x = -3$$

$$x^2 - \frac{3}{5}x = -\frac{3}{10}$$

$$x^2 - \frac{3}{5}x + \frac{9}{100} = -\frac{3}{10} + \frac{9}{100}$$

$$\sqrt{(x-\frac{3}{10})^2} = \sqrt{\frac{-21}{100}}$$

$$|x-\frac{3}{10}| = \frac{i\sqrt{21}}{10}$$

$$x = \frac{3 \pm i\sqrt{21}}{10}$$

$$9. -5 = 8x^2 + 6x$$

$$x^2 + \frac{3}{4}x + \frac{9}{64} = \frac{-5}{8} + \frac{9}{64}$$

$$\sqrt{(x+\frac{3}{8})^2} = \sqrt{\frac{-31}{64}}$$

$$|x+\frac{3}{8}| = \frac{i\sqrt{31}}{8}$$

$$x = \frac{-3 \pm i\sqrt{31}}{8}$$

p-37 checks

#6 $4x = x^2 + 5x + 4$ Verifying $x = \frac{-1 \pm 2\sqrt{5}}{2}$

$$4\left(\frac{-1 + 2\sqrt{5}}{2}\right) = \left(\frac{-1 + 2\sqrt{5}}{2}\right)^2 + 5\left(\frac{-1 + 2\sqrt{5}}{2}\right) + 4$$

$$\begin{aligned} 2(-1 + 2\sqrt{5}) &= \frac{1 - 2i\sqrt{5} - 15}{4} + \frac{-5 + 5i\sqrt{5}}{2} + \frac{8}{2} \\ -2 + 2i\sqrt{5} &= \frac{-14 - 2i\sqrt{5}}{4} + \frac{-5 + 5i\sqrt{5}}{2} + \frac{8}{2} \\ &= \frac{-7 - i\sqrt{5}}{2} + \frac{-5 + 5i\sqrt{5}}{2} + \frac{8}{2} \\ &= \frac{-4 + 4i\sqrt{5}}{2} \\ &= -2 + 2i\sqrt{5} \checkmark \end{aligned}$$

Also

$$4\left(\frac{-1 - 2\sqrt{5}}{2}\right) = \left(\frac{-1 - 2\sqrt{5}}{2}\right)^2 + 5\left(\frac{-1 - 2\sqrt{5}}{2}\right) + 4$$

$$\begin{aligned} 2(-1 - 2\sqrt{5}) &= \frac{1 + 2i\sqrt{5} - 15}{4} + \frac{-5 - 5i\sqrt{5}}{2} + \frac{8}{2} \\ -2 - 2i\sqrt{5} &= \frac{-14 + 2i\sqrt{5}}{4} + \frac{-5 - 5i\sqrt{5}}{2} + \frac{8}{2} \\ &= \frac{-7 + i\sqrt{5}}{2} + \frac{-5 - 5i\sqrt{5}}{2} + \frac{8}{2} \\ &= \frac{-4 - 4i\sqrt{5}}{2} \end{aligned}$$

$$-2 - 2i\sqrt{5} = -2 - 2i\sqrt{5} \checkmark$$

#7 $x^2 - 4x + 20 = 0$ Verifying $x = 2 \pm 4i$

$$(2 + 4i)^2 - 4(2 + 4i) + 20 = 0$$

$$4 + 16i - 16 - 8 - 16i + 20$$

$$0 = 0 \checkmark$$

Also $(2 - 4i)^2 - 4(2 - 4i) + 20 =$

$$4 - 16i - 16 - 8 + 16i + 20 =$$

$$0 = 0 \checkmark$$

(#8) $6x + 23 = 10x^2 + 26$ Verifying $x = \frac{3 \pm i\sqrt{21}}{10}$

$$6\left(\frac{3+i\sqrt{21}}{10}\right) + 23 = 10\left(\frac{3+i\sqrt{21}}{10}\right)^2 + 26$$
$$3\left(\frac{3+i\sqrt{21}}{5}\right) - 23 = -23$$

$$\frac{9+3i\sqrt{21}}{5} = 10\left(\frac{9+6i\sqrt{21}-21}{100}\right) + 3$$
$$= \frac{-12+6i\sqrt{21}}{10}$$
$$= \frac{-6+3i\sqrt{21}}{5} + \frac{15}{5}$$
$$= \frac{9+3i\sqrt{21}}{5} \quad \checkmark$$

Also

$$6\left(\frac{3-i\sqrt{21}}{10}\right) + 23 = 10\left(\frac{3-i\sqrt{21}}{10}\right)^2 + 26$$
$$3\left(\frac{3-i\sqrt{21}}{5}\right) - 23 = -23$$
$$\frac{9-3i\sqrt{21}}{5} = 10\left(\frac{9-6i\sqrt{21}-21}{100}\right) + 3$$
$$= \frac{-12-6i\sqrt{21}}{10} + 3$$
$$= \frac{-6-3i\sqrt{21}}{5} + \frac{15}{5}$$
$$= \frac{9-3i\sqrt{21}}{5} \quad \checkmark$$

(#9) $-5 = 8x^2 + 6x$ | Verifying $x = \frac{-3 \pm i\sqrt{31}}{8}$

$$8\left(\frac{-3+i\sqrt{31}}{8}\right)^2 + 6\left(\frac{-3+i\sqrt{31}}{8}\right) = -5$$

$$8\left(\frac{9-6i\sqrt{31}-31}{64}\right) + \frac{-18+6i\sqrt{31}}{8} =$$

$$\frac{-22-6i\sqrt{31}}{8}$$

$$\frac{-11-3i\sqrt{31}}{4} + \frac{-9+3i\sqrt{31}}{4} =$$

$$\frac{-20}{4} = -5 \checkmark$$

Also

$$8\left(\frac{-3-i\sqrt{31}}{8}\right)^2 + 6\left(\frac{-3-i\sqrt{31}}{8}\right) = -5$$

$$8\left(\frac{9+6i\sqrt{31}-31}{64}\right) + \frac{-18-6i\sqrt{31}}{8}$$

$$\frac{-22+6i\sqrt{31}}{8}$$

$$\frac{-11+3i\sqrt{31}}{4} + \frac{-9-3i\sqrt{31}}{4}$$

$$\frac{-20}{4} = -5 \checkmark$$

5.2K Solving Quadratic Equations by Completing the Square to Find Real or Complex Solutions

10. Emma hits a golf ball off the tee. The height of the ball is given by $h(x) = -16x^2 + 4000x + 3248$ where h is the height in yards above the ground and x is the horizontal distance from the tee in yards. How far does Emma hit the ball? (Solve by Completing the Square and round your solution to the nearest hundredth.)

$$\begin{aligned}
 -16x^2 + 4000x &= -3248 \\
 x^2 - 250x + 15625 &= 203 + 15625 \\
 \sqrt{(x-125)^2} &= \sqrt{15828} \\
 |x-125| &= 125.81 \\
 x-125 &= \pm 125.81 \\
 x &\approx 250.81 \text{ yds} \\
 x &\approx 0.81 \text{ x hundreds}
 \end{aligned}$$

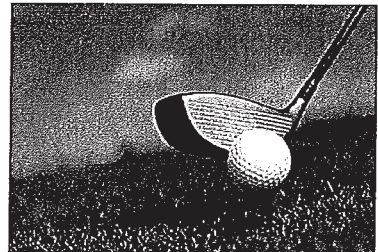

11. Gail and Veronica are fixing a leak in a roof. Gail is working on the roof and Veronica is tossing up supplies to Gail. When Gail tosses up a tape measure, the height h , in feet, of the object above the ground t seconds after Veronica tosses it is $h(t) = -16t^2 + 32t + 5$. Gail can catch the object any time it is above 17 feet. How much time does Gail have to try to catch the tape measure? (Solve by Completing the Square and round your solution to the nearest hundredth.)

$$\begin{aligned}
 -16t^2 + 32t + 5 &= 17 \\
 -16t^2 + 32t &= 12 \\
 t^2 - 2t + 1 &= \frac{3}{4} + 1 \\
 \sqrt{(t-1)^2} &= \sqrt{\frac{7}{4}} \\
 |t-1| &= \frac{\sqrt{7}}{2} \\
 t-1 &= \pm \frac{\sqrt{7}}{2} \\
 t &= 1 \pm \frac{\sqrt{7}}{2} \\
 t &= 1/2 \text{ sec or } t = 1\frac{1}{2} \text{ sec} \\
 \text{So Gail can catch tape measure} \\
 \text{at } \left(\frac{1}{2} < t < 1\frac{1}{2} \text{ seconds}\right)
 \end{aligned}$$



12. For which values of y , given $y = x^2 + bx + \left(\frac{b}{2}\right)^2$, will you find 2 complex solutions?

when $y < 0$

13. Solve the following quadratic for x by **Completing the Square**.

What is the result?

$$\begin{aligned}
 \frac{ax^2 + bx + c}{a} &= 0 \\
 x^2 + \frac{bx}{a} &= -\frac{c}{a} \\
 x^2 + \frac{bx}{a} + \frac{b^2}{4a^2} &= -\frac{c}{a} + \frac{b^2}{4a^2} \\
 \sqrt{\left(x + \frac{b}{2a}\right)^2} &= \sqrt{\frac{-4ac + b^2}{4a^2}} \\
 \left|x + \frac{b}{2a}\right| &= \sqrt{\frac{b^2 - 4ac}{4a^2}}
 \end{aligned}$$

$$\begin{aligned}
 x + \frac{b}{2a} &= \frac{\pm \sqrt{b^2 - 4ac}}{2a} \\
 x &= \frac{-b \pm \sqrt{b^2 - 4ac}}{2a}
 \end{aligned}$$

The Quadratic Formula!

Section 5.2K

5.2L Solving Quadratic Equations Using the Quadratic Formula to Find Real Solutions

1. Describe a situation where you would HAVE to use the quadratic formula to solve a quadratic equation if you did not want to graph it.

If the quadratic equation does not factor, the roots are either irrational or imaginary.

#2 - 7: Determine a, b, and c and then solve using the quadratic formula. Remember to show ALL work.

2. $2x^2 - 5x - 3 = 0$

a: 2 b: -5 c: -3

$x = \frac{5 \pm \sqrt{25 - 4(2)(-3)}}{2(2)}$

$x = \frac{5 \pm \sqrt{49}}{4}$
 $\left\{ \begin{array}{l} \frac{5+7}{4} \quad x = 3 \\ \text{OR} \\ \frac{5-7}{4} \quad x = -\frac{1}{2} \end{array} \right.$

Could you have solved by factoring? Explain.

Yes! $(2x+1)(x-3) = 0$ (49 is a perfect square #)
 $x = -\frac{1}{2}$ or $x = 3$

3. $x^2 - 7x + 9 = 0$

a: 1 b: -7 c: 9

$x = \frac{7 \pm \sqrt{(-7)^2 - 4(1)(9)}}{2(1)}$

$x = \frac{7 \pm \sqrt{13}}{2}$

Could you have solved by factoring? Explain:

No! $b^2 - 4ac$ is not a perfect square
 13 " " " " "

4. $5x^2 + 3x = 1$

a: 5 b: 3 c: -1

$x = \frac{-3 \pm \sqrt{(3)^2 - 4(5)(-1)}}{2(5)}$

$x = \frac{-3 \pm \sqrt{29}}{10}$

Could you have solved by factoring? Explain.

No! 29 is not a perfect square #

5. $x^2 + x - 1 = 0$

a: 1 b: 1 c: -1

$x = \frac{-1 \pm \sqrt{(1)^2 - 4(1)(-1)}}{2(1)}$

$x = \frac{-1 \pm \sqrt{5}}{2}$

Could you have solved by factoring? Explain:

No! 5 is not a perfect square #

5.2L Solving Quadratic Equations Using the Quadratic Formula to Find Real Solutions

#2 - 7 (continued): Determine a, b, and c and then solve using the quadratic formula. Remember to show ALL work.

6. $9x^2 + 6x - 1 = 0$

a: 9 b: 6 c: -1

$$x = \frac{-6 \pm \sqrt{(6)^2 - 4(9)(-1)}}{2(9)}$$

$$x = \frac{-6 \pm \sqrt{72}}{18} = \frac{-6 \pm 6\sqrt{2}}{18}$$

$$x = \frac{-1 \pm \sqrt{2}}{3}$$

7. $2x^2 + 3x + 2 = 3$

a: 2 b: 3 c: -1

$$x = \frac{-3 \pm \sqrt{(3)^2 - 4(2)(-1)}}{2(2)}$$

$$x = \frac{-3 \pm \sqrt{17}}{4}$$

8. A cliff diver jumps up and away from the cliff as he jumps. His path can be modeled by the equation $h(t) = -16t^2 + 12t + 25$, where h is the height, in feet, of the diver at a specific time, t , in seconds. How long will it take for the diver to reach the water below? Solve using the quadratic formula. Round answers to the nearest hundredth. (Hint: When the diver hits the water, he is at a height of 0 ft.)

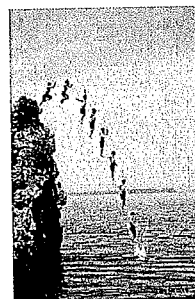

a = -16 b = 12 c = 25

$$x = \frac{-12 \pm \sqrt{(12)^2 - 4(-16)(25)}}{2(-16)}$$

$$x = \frac{-12 \pm \sqrt{1744}}{-32}$$

$$x \approx -0.93 \text{ so } 1.68 \text{ seconds}$$

$$x \approx 1.68$$

9. The volcanic cinder cone Puu Puai in Hawaii was formed in 1959 when a massive "lava fountain" erupted at Kilauea Iki Crater, shooting lava hundreds of feet into the air. When the eruption was most intense, the height h (in feet) of the lava t seconds after being ejected from the ground could be modeled by $h(t) = -16t^2 + 352t$. Solve using any method you have learned. Round your answers to the nearest hundredth.

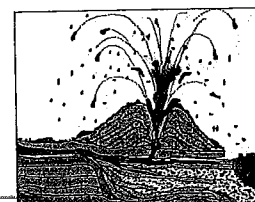

a) How long was the lava in the air?

$$-16t^2 + 352t = 0$$

$$-16t(t - 22) = 0$$

$$t = 0 \text{ or } t = 22 \text{ secs}$$

b) How long did it take the lava to reach its maximum height of 1936 feet?

$$-16t^2 + 352t = 1936$$

$$-16t^2 + 352t - 1936 = 0$$

a = -16 b = 352 c = -1936

$$t = \frac{-352 \pm \sqrt{(352)^2 - 4(-16)(-1936)}}{2(-16)}$$

$$t = \frac{-352 \pm \sqrt{0}}{-32}$$

$$t = 11 \text{ seconds}$$

Section 5.2L

5.2M Solving Quadratic Equations Using the Quadratic Formula to Find Real or Complex Solutions

#1 – 3: Review: Simplify the following radicals.

1. $\frac{\sqrt{-12}}{\sqrt{-1 \cdot 4 \cdot 3}}$
 $\frac{2i\sqrt{3}}{2i\sqrt{3}}$

2. $\frac{\sqrt{24}}{\sqrt{4 \cdot 6}}$
 $\frac{2\sqrt{6}}{2\sqrt{6}}$

3. $\frac{\sqrt{-16}}{\sqrt{-1 \cdot 16}}$
 $\frac{4i}{4i}$

#4-9: The following solutions were found using the quadratic formula but are not simplified all the way. Put the solutions in simplest form. No decimals allowed!

4. $x = \frac{-2 \pm 4}{2}$
 $x = 1$ or $x = -3$

5. $x = \frac{-6 \pm \sqrt{0}}{4}$
 $x = -\frac{3}{2}$

6. $x = \frac{3 \pm \sqrt{-4}}{2}$
 $x = \frac{3 \pm 2i}{2}$

7. $x = \frac{-6 \pm \sqrt{-11}}{2(2)}$
 $x = \frac{-6 \pm i\sqrt{11}}{4}$

8. $x = \frac{-2 \pm \sqrt{-20}}{2(1)}$
 $x = -1 \pm i\sqrt{5}$

9. $x = \frac{-2 \pm \sqrt{64}}{2(1)}$
 $x = 3$ or $x = -5$

10. Carter solved the following quadratic equation using the quadratic formula – his work is shown below. However, he did not simplify his answer correctly. Find his mistake(s) and then simplify the solution correctly.

Error Line 6
 $x = \frac{-6 \pm 2i}{2} = -3 \pm i$
 $x = -3 \pm i$

Line 1	$x^2 + 6x + 10 = 0$
Line 2	$a = 1, b = 6, c = 10$
Line 3	$x = \frac{-6 \pm \sqrt{(6)^2 - 4(1)(10)}}{2(1)}$
Line 4	$x = \frac{-6 \pm \sqrt{-4}}{2}$
Line 5	$x = \frac{-6 \pm 2i}{2}$
Line 6	$x = -3 \pm 2i$

5.2M Solving Quadratic Equations Using the Quadratic Formula to Find Real or Complex Solutions

#11 – 13: Solve using the quadratic formula. Be sure to simplify your answer, keeping your answers exact (no decimals approximations). Remember to show ALL work.

11. $x^2 + 6x = -2$
 $x^2 + 6x + 2 = 0$
 $a = 1 \quad b = 6 \quad c = 2$

$x = \frac{-6 \pm \sqrt{(6)^2 - 4(1)(2)}}{2(1)}$
 $x = \frac{-6 \pm \sqrt{28}}{2} = \frac{-6 \pm 2\sqrt{7}}{2}$
 $x = -3 \pm \sqrt{7}$

12. $2x^2 - 8x = -8$
 $2x^2 - 8x + 8 = 0$
 $2(x^2 - 4x + 4) = 0$
 $x^2 - 4x + 4 = 0$
 $a = 1 \quad b = -4 \quad c = 4$

$x = \frac{4 \pm \sqrt{(-4)^2 - 4(1)(4)}}{2(1)}$
 $x = \frac{4 \pm \sqrt{0}}{2}$
 $x = 2$

13. $5x^2 - 13x + 9 = 0$
 $a = 5 \quad b = -13 \quad c = 9$

$x = \frac{13 \pm \sqrt{(-13)^2 - 4(5)(9)}}{2(5)}$
 $x = \frac{13 \pm \sqrt{-11}}{2(5)}$
 $x = \frac{13 \pm i\sqrt{11}}{10}$

14. The path of an object thrown straight up in the air with an initial velocity of 40 feet per second and from an initial height of 4 feet can be modeled by the equation $h(t) = -16t^2 + 40t + 4$, where h is the height of the object at time t .

a) How long does the object remain in the air before landing (height = 0)? Put your answer in decimal form, rounded to the nearest tenth of a second.

$a = -16 \quad b = 40 \quad c = 4$
 $x = \frac{-40 \pm \sqrt{(40)^2 - 4(-16)(4)}}{2(-16)}$
 $x = \frac{-40 \pm \sqrt{1856}}{-32} = \frac{-40 \pm 43.08}{-32}$ -0.10 extraneous
 2.6 sec

b) From part a) of this problem, the quadratic formula gives you two answers. How did you know which answer to choose? *Since $t = 0$ means time when object is initially thrown, positive time means time after the throw was started. Negative time implies time before the object was thrown, which doesn't make sense here.*

c) How long is the object in the air when it reaches a height of 25 feet?

$-16t^2 + 40t + 4 = 25$
 $-16t^2 + 40t - 21 = 0$
 $a = -16 \quad b = 40 \quad c = -21$
 $t = \frac{-40 \pm \sqrt{(40)^2 - 4(-16)(-21)}}{2(-16)}$
 $\text{After } 0.75 \text{ secs and again at } 1.75 \text{ secs}$

Section 5.2M

5.2N Solving Quadratic Equations - Choosing the Best Method: Part I

1. List 5 ways to solve a quadratic equation:

- > Use a graphing utility to find real zeros
- > Factor and use the zero product property
- > Use square roots
- > Complete the Square
- > Use the Quadratic Formula

#2 - 3: Solve the following quadratic equations using the indicated methods.

2. $x^2 - x = 6$ $x^2 - x - 6 = 0$

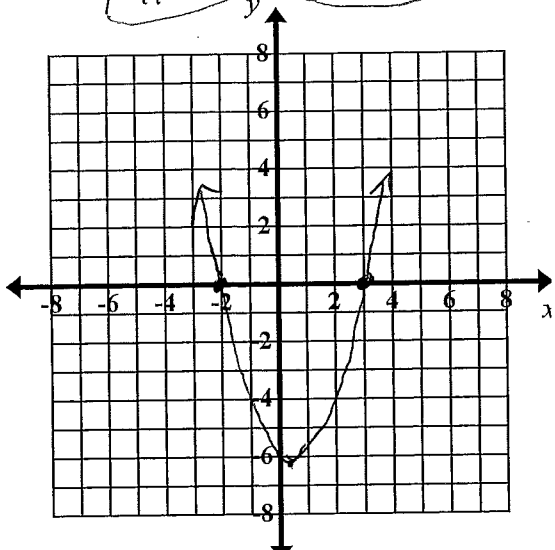
<p>Graph: $x = -2$ or $x = 3$</p> 	<p>Factor:</p> $x^2 - x = 6$ $x^2 - x - 6 = 0$ $(x-3)(x+2) = 0$ <div style="border: 1px solid black; padding: 5px; width: fit-content; margin: 5px auto;">$x = 3$ or $x = -2$</div>
<p>Quadratic Formula: $a = 1$ $x^2 - x - 6 = 0$ $b = -1$ $c = -6$</p> $x = \frac{1 \pm \sqrt{(-1)^2 - 4(1)(-6)}}{2(1)}$ <div style="display: flex; align-items: center; margin-top: 10px;"> $\frac{1 \pm \sqrt{25}}{2}$ <div style="margin-left: 20px;"> $\rightarrow \frac{1+5}{2} = 3$ $\rightarrow \frac{1-5}{2} = -2$ </div> </div>	<p>Solution(s):</p> <div style="border: 1px solid black; padding: 10px; width: fit-content; margin: 5px auto;">$x = 3$ or $x = -2$</div>
<p>Which method was the most efficient for this problem and why?</p> <p>Factoring Method is the fastest and yields rational solutions safely.</p>	

5.2N Solving Quadratic Equations – Choosing the Best Method: Part I

#2 – 3 (continued): Solve the following quadratic equations using the indicated methods.

3. $x^2 - 3 = 0$

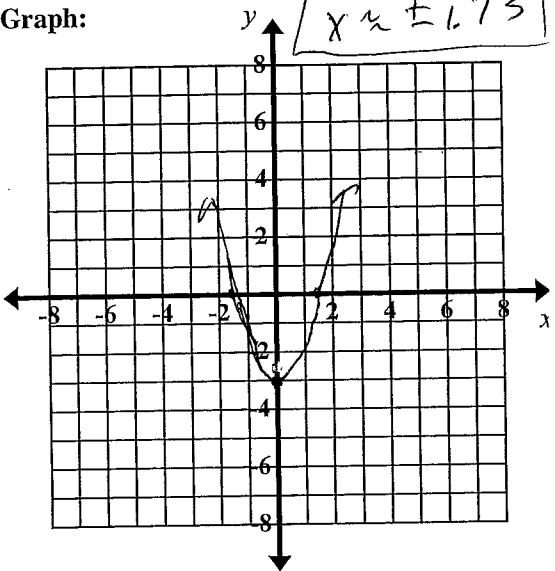
<p>Graph:</p> 	<p>Square Root:</p> $x^2 - 3 = 0$ $\sqrt{x^2} = \sqrt{3}$ $ x = \sqrt{3}$ <div style="border: 1px solid black; padding: 5px; width: fit-content; margin: 5px auto;">$x = \pm\sqrt{3}$</div>
<p>Quadratic Formula: $a=1$ $b=0$ $c=-3$</p> $x^2 - 3 = 0$ $x = \frac{-0 \pm \sqrt{0^2 - 4(1)(-3)}}{2(1)}$ <div style="border: 1px solid black; padding: 5px; width: fit-content; margin: 5px auto;">$x = \frac{0 \pm \sqrt{12}}{2} = \frac{\pm 2\sqrt{3}}{2} = \pm\sqrt{3}$</div>	<p>Solution(s):</p> <div style="border: 1px solid black; padding: 5px; width: fit-content; margin: 5px auto;">$x = \pm\sqrt{3}$</div>
<p>Which method was the most efficient for this problem and why?</p> <p>The SQUARE ROOT method There was no x term, OR $b=0$</p>	

4. List the method(s) for solving quadratic equations that:

- a) You can *always* use but often it only gives *approximate* answers.
graphing calculator (but can't use to find complex/imaginary solns).
- b) You can *always* use to solve quadratic equations.
Completing the Square and Quadratic Formula
- c) You can only use *sometimes* to solve quadratic equations.
Factoring or Square Root

5.2N Solving Quadratic Equations - Choosing the Best Method: Part I

#5 - 7: For each equation, determine an effective method for solving the quadratic equation and explain why you chose that method. Solve the quadratic equation with the method of your choice, keeping the answer exact (no decimal approximations).

5. $2x^2 + 5x - 3 = 0$ *It factored easily.*
 $(2x-1)(x+3)$
 $x = \frac{1}{2}$ or $x = -3$

6. $-4x^2 + 4000x = 0$ *It factored easily.*
 $-4x(x-1000) = 0$
 $x = 0$ or $x = 1000$

7. $x^2 + 7x - 18 = 0$ *It factored easily.*
 $(x+9)(x-2) = 0$
 $x = -9$ or $x = 2$

#8 - 11: Determine an answer for each situation. Be sure to clearly record your thinking.

8. The product of two consecutive integers is 72. Find the two numbers.
 let $n =$ any integer
 $n+1 =$ Consec. int (larger)
 $n(n+1) = 72$
 $n^2 + n - 72 = 0$
 $(n-8)(n+9) = 0$
 $n = 8$ or $n = -9$
 $n+1 = 9$ or $n+1 = -8$
The 2#s are 8 and 9 or -9 and -8

9. The length of a rectangle exceeds its width by 3 inches. The area of the rectangle is 70 square inches. Find its dimensions.
 $x+3$
 x $\boxed{70}$
 $x(x+3) = 70$
 $x^2 + 3x - 70 = 0$
 $(x+10)(x-7) = 0$
 $x = -10$ or $x = 7$ \Rightarrow $\boxed{\text{width} = 7 \text{ in}}$
 $\boxed{\text{length} = 10 \text{ in}}$
extraneous

5.2N Solving Quadratic Equations – Choosing the Best Method: Part I

#5 – 7: For each equation, determine an effective method for solving the quadratic equation and explain why you chose that method. Solve the quadratic equation with the method of your choice, keeping the answer exact (no decimal approximations).

5. $2x^2 + 5x - 3 = 0$ It factored easily.
 $(2x-1)(x+3)$
 $x = \frac{1}{2}$ or $x = -3$

6. $-4x^2 + 4000x = 0$ It factored easily.
 $-4x(x - 1000) = 0$
 $x = 0$ or $x = 1000$

7. $x^2 + 7x - 18 = 0$ It factored easily.
 $(x+9)(x-2) = 0$
 $x = -9$ or $x = 2$

#8 – 11: Determine an answer for each situation. Be sure to clearly record your thinking.

8. The product of two consecutive integers is 72. Find the two numbers.
 let $n =$ any integer
 $n+1 =$ Consec. int (larger)
 $n(n+1) = 72$
 $n^2 + n - 72 = 0$
 $(n-8)(n+9)$
 $n = 8$ or $n = -9$
 $n+1 = 9$ $n+1 = -8$
 The 2 #s are 8 and 9 or -9 and -8

9. The length of a rectangle exceeds its width by 3 inches. The area of the rectangle is 70 square inches. Find its dimensions.

$x+3$
 $x \begin{array}{|c|} \hline 70 \\ \hline \end{array}$ $x(x+3) = 70$
 $x^2 + 3x - 70 = 0$
 $(x+10)(x-7) = 0$
 $x = -10$ $x = 7$ \Rightarrow width = 7 in
 length = 10 in
 extraneous

5.2N Solving Quadratic Equations – Choosing the Best Method: Part I

#8 – 11 (continued): Determine an answer for each situation. Be sure to clearly record your thinking.

10. Suzie wants to build a garden that has three separate rectangular sections. She wants to fence around the whole garden and between each section as shown. The plot is twice as long as it is wide and the total area is 200 square feet. How much fencing does Suzie need?

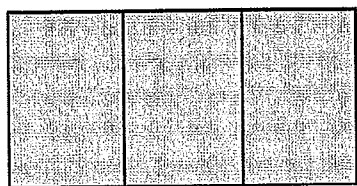

2x

$$\begin{aligned}
 x(2x) &= 200 \\
 2x^2 &= 200 \\
 \sqrt{x^2} &= \sqrt{100} \\
 |x| &= 10 \\
 x &= \pm 10 \\
 \text{width } &10 \\
 \text{length } &20
 \end{aligned}$$

$$\begin{aligned}
 \text{Fencing} &= \text{Perimeter} + 2x \\
 &= 2L + 2w + 2x \\
 &= 2(20) + 2(10) + 2x \\
 &= 8x \\
 &= 8(10)
 \end{aligned}$$

Fencing = 80 feet

11. Mike wants to fence three sides of a rectangular patio that is adjacent to the back of his house. The area of the patio is 192 ft² and the length is 4 feet longer than the width. Find how much fencing Mike will need.

$$\begin{aligned}
 x(x+4) &= 192 \\
 x^2 + 4x - 192 &= 0 \\
 (x-12)(x+16) &= 0 \\
 x &= 12 \text{ or } x = -16 \\
 &\text{extraneous}
 \end{aligned}$$

$$\begin{aligned}
 \text{Fencing} &= x + (x+4) + x \\
 &= 3x + 4 \\
 &= 3(12) + 4
 \end{aligned}$$

Fencing = 40 feet

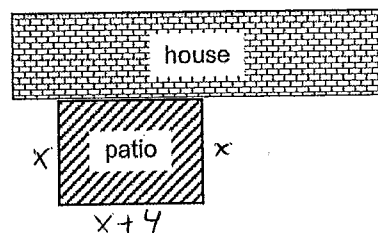

#12 – 13: Solve each quadratic equation 2 different ways. Record the method that you are using for each.
(Square Roots – Factoring – Completing the Square – Quadratic Formula)

12. $2x^2 + 3 = 21$

<p>Method 1: Square Roots</p> $ \begin{aligned} 2x^2 + 3 &= 21 \\ 2x^2 &= 18 \\ \sqrt{x^2} &= \sqrt{9} \\ x &= 3 \\ \boxed{x = \pm 3} \end{aligned} $	<p>Method 2: Factoring</p> $ \begin{aligned} 2x^2 + 3 &= 21 \\ 2x^2 - 18 &= 0 \\ 2(x^2 - 9) &= 0 \\ 2(x+3)(x-3) &= 0 \\ \boxed{x = -3 \text{ or } x = 3} \end{aligned} $
<p>Solution(s): $\boxed{x = \pm 3}$</p> <p>Square Roots because there was no x-term.</p> <p>Factoring since difference of squares pattern is easy.</p>	<p>Why did you choose the two methods that you did and which do you feel is more efficient?</p> <p>Square Roots has less chance for a careless sign error. Also, students have been solving with square roots longer than they have been factoring.</p>

5.2N Solving Quadratic Equations – Choosing the Best Method: Part I

#12 – 13 (continued): Solve each quadratic equation 2 different ways. Record the method that you are using for each. (Square Roots – Factoring – Completing the Square – Quadratic Formula)

13. The length of a rectangular pool is 10 meters more than its width. The area of the pool is 875 square meters. Find the dimensions of the pool.

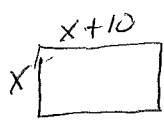

<p>Method 1: Completing the Square</p> $x(x+10) = 875$ $x^2 + 10x + 25 = 875 + 25$ $\sqrt{(x+5)^2} = \sqrt{900}$ $ x+5 = 30$ $x+5 = \pm 30$ $x = -5 \pm 30$ <p style="margin-left: 150px;">← 25 ← 35 extraneous</p> <div style="border: 1px solid black; padding: 5px; width: fit-content;"> <p>width = 25 m length = 35 m</p> </div>	<p>Method 2: Factoring</p> $x(x+10) = 875$ $x^2 + 10x - 875 = 0$ $(x-25)(x+35) = 0$ $x = 25 \quad x = -35$ <p style="margin-left: 100px;">x+10 = 35 extraneous</p> <div style="border: 1px solid black; border-radius: 50%; padding: 10px; width: fit-content; margin: 10px auto;"> <p>width = 25 m length = 35 m</p> </div>
<p>Solution(s): width = 25 m length = 35 m</p> <p>Complete the square already had the constant isolated and it was easy to find $(\frac{b}{2})^2$. Factoring was nice since $a=1$.</p>	<p>Why did you choose the two methods that you did and which do you feel is more efficient? Complete the square was more efficient. Since $(\frac{b}{2})^2$ was a whole #, plus the square root property is well ingrained. Factoring might have taken longer to find 2 integers with a product of -875.</p>

#14 – 17: Solve the following quadratic equations with the method of your choice. Verify that the answer is correct:

14. $3x^2 + 6x = -10$
 $3x^2 + 6x + 10 = 0$
 $a = 3 \quad b = 6 \quad c = 10$

Use Quad. Formula:

$$x = \frac{-6 \pm \sqrt{(6)^2 - 4(3)(10)}}{2(3)}$$

$$x = \frac{-6 \pm \sqrt{-84}}{6}$$

$$x = \frac{-6 \pm 2i\sqrt{21}}{6} = \frac{-3 \pm i\sqrt{21}}{3}$$

✓ Verify that your answer(s) are solution(s):

$$3\left(\frac{-3+i\sqrt{21}}{3}\right)^2 + 6\left(\frac{-3+i\sqrt{21}}{3}\right) = -10 \quad \text{and} \quad 3\left(\frac{-3-i\sqrt{21}}{3}\right)^2 + 6\left(\frac{-3-i\sqrt{21}}{3}\right) = -10$$

$$3\left(\frac{9-6i\sqrt{21}-21}{9}\right) + 2(-3+i\sqrt{21}) \qquad 3\left(\frac{9+6i\sqrt{21}-21}{9}\right) + 2(-3-i\sqrt{21})$$

$$\frac{-12-6i\sqrt{21}}{3} \qquad \frac{-12+6i\sqrt{21}}{3}$$

$$-4-2i\sqrt{21} - 6 + 2i\sqrt{21} = -10 \qquad -4 + 2i\sqrt{21} - 6 - 2i\sqrt{21} = -10$$

$$-10 = -10 \checkmark \qquad -10 = -10 \checkmark$$

5.2N Solving Quadratic Equations – Choosing the Best Method: Part I

#14 – 17 (continued): Solve the following quadratic equations with the method of your choice. Verify that the answer is correct:

15. $-3x^2 + 12x + 1 = 0$
 $a = -3$ $b = 12$ $c = 1$

$$x = \frac{-12 \pm \sqrt{(12)^2 - 4(-3)(1)}}{2(-3)}$$

$$= \frac{-12 \pm \sqrt{156}}{-6}$$

$$x = \frac{-12 \pm 2\sqrt{39}}{-6} \Rightarrow x = \frac{6 \pm \sqrt{39}}{3}$$

✓Verify that your answer(s) are solution(s):

$$-3\left(\frac{6 + \sqrt{39}}{3}\right)^2 + 12\left(\frac{6 + \sqrt{39}}{3}\right) + 1 = 0$$

$$-3\left(\frac{36 + 12\sqrt{39} + 39}{9}\right) + 4(6 + \sqrt{39}) + 1$$

$$\frac{75 + 12\sqrt{39}}{-3}$$

16. $x^2 + 6x + 9 = 0$
 $(x+3)(x+3) = 0$
 $x = -3$

$$-25 - 4\sqrt{39} + 24 + 4\sqrt{39} + 1 = 0$$

0 = 0 ✓

Also $-3\left(\frac{6 - \sqrt{39}}{3}\right)^2 + 12\left(\frac{6 - \sqrt{39}}{3}\right) + 1 = 0$

$$-3\left(\frac{36 - 12\sqrt{39} + 39}{9}\right) + 4(6 - \sqrt{39}) + 1$$

✓Verify that your answer(s) are solution(s):

$$(-3)^2 + 6(-3) + 9 = 0$$

$$9 - 18 + 9 = 0$$

0 = 0 ✓

$$\frac{75 - 12\sqrt{39}}{-3}$$

$$-25 + 4\sqrt{39} + 24 - 4\sqrt{39} + 1 = 0$$

0 = 0 ✓

17. $81x^2 + 1 = 0$

$$\frac{81x^2}{81} = \frac{-1}{81}$$

$$\sqrt{x^2} = \sqrt{\frac{-1}{81}}$$

$$|x| = \frac{i}{9}$$

$x = \pm \frac{i}{9}$

✓Verify that your answer(s) are solution(s):

$$81\left(\frac{i}{9}\right)^2 + 1 = 0$$

$$81\left(\frac{-i}{9}\right)^2 + 1 = 0$$

$$81\left(\frac{-1}{81}\right) + 1$$

$$-1 + 1 = 0 \checkmark$$

$$81\left(\frac{(-1)(-1)(i)(i)}{81}\right)$$

$$81\left(\frac{i^2}{81}\right)$$

$$81\left(\frac{-1}{81}\right) + 1 = 0 \checkmark$$

5.2N Solving Quadratic Equations – Choosing the Best Method: Part I

18. The height h (in feet) above the ground of a baseball depends upon the time t (in seconds) it has been in flight. Joe takes a mighty swing and hits a bloop single whose height is described approximately by the equation $h = 80t - 16t^2$.

a) How long is the ball in the air?

$$-16t^2 + 80t = 0$$

$$-16t(t - 5) = 0$$

$$t = 0 \text{ or } t = 5 \text{ seconds}$$

extraneous

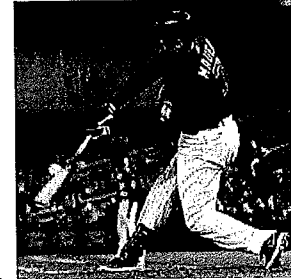

b) When does the ball reach its maximum height? Use Graphing Calc.
After 2.5 seconds

c) What is the maximum height?

100 ft

d) It takes approximately 0.92 seconds for the ball to reach a height of 60 feet. On its way back down, the ball is again 60 feet above the ground. What is the value of t when this happens?

Add the line in $y_2 = 60$ and use calculate intersect to get

$$t \approx 4.08 \text{ seconds}$$

Section 5.2N

5.2N Solving Quadratic Equations – Choosing the Best Method: Part I

This page intentionally left blank

5.20 Solving Quadratic Equations – Choosing the Best Method: Part II

#1 – 5: Four equations and one situation are given. Solve one by the square root property, one by factoring, one by completing the square, one using the quadratic formula, and one by graphing. Express your answers in simplest radical form. Verify your answer

1. $2x^2 = -7x + 15$ 2. $x^2 - 2x - 15 = 0$ 3. $x^2 + 12x = 20$ 4. $(x-3)^2 = 8$

5. A group of friends hiked to Havasupai Point in Grand Canyon National Park. The Colorado River was 4755 feet below them. A rock was thrown upward at an initial velocity of 24 feet per second. The rock's height t seconds after it was thrown upward is given by the function $h(t) = -16t^2 + 24t + 4755$. How long did it take for the rock to hit the river?

<p>Solve by: Square Root Property</p> <p># <u>4</u> equation: $\sqrt{(x-3)^2} = \sqrt{8}$</p> <p>Solve: $x-3 = 2\sqrt{2}$ $x-3 = \pm 2\sqrt{2}$ $x = 3 \pm 2\sqrt{2}$</p> <p>Solution(s): $x = 3 \pm 2\sqrt{2}$</p> <p>✓ Verify that your answer(s) are solution(s) $((3+2\sqrt{2})-3)^2 = 8$ $((3-2\sqrt{2})-3)^2 = 8$ $(2\sqrt{2})^2 = 8$ $(-2\sqrt{2})^2 = 8$ $8 = 8$ ✓ $8 = 8$ ✓</p>	<p>Solve by: Factoring</p> <p># <u>2</u> equation: $x^2 - 2x - 15 = 0$</p> <p>Solve: $(x-5)(x+3) = 0$ $x = 5$ or $x = -3$</p> <p>Solution(s): $x = 5$ or $x = -3$</p> <p>✓ Verify that your answer(s) are solution(s) $(5)^2 - 2(5) - 15 = 0$ $(-3)^2 - 2(-3) - 15 = 0$ $25 - 10 - 15 = 0$ $9 + 6 - 15 = 0$ $0 = 0$ ✓ $0 = 0$ ✓</p>
--	---

<p>Solve by: Completing the Square</p> <p># <u>3</u> equation: $x^2 + 12x = 20$</p> <p>Solve: $x^2 + 12x + 36 = 20 + 36$ $\sqrt{(x+6)^2} = \sqrt{56}$ $x+6 = 2\sqrt{14}$ $x = -6 \pm 2\sqrt{14}$</p> <p>Solution(s): $x = -6 \pm 2\sqrt{14}$</p> <p>✓ Verify that your answer(s) are solution(s) $(-6+2\sqrt{14})^2 + 12(-6+2\sqrt{14}) = 20$ $(-6-2\sqrt{14})^2 + 12(-6-2\sqrt{14}) = 20$ $(36+24\sqrt{14}+56)$ $(36+24\sqrt{14}+56)$ $92+24\sqrt{14}-72+24\sqrt{14}$ $92+24\sqrt{14}-72-24\sqrt{14}$ $20 = 20$ ✓ $20 = 20$ ✓</p>	<p>Solve by: Using the Quadratic Formula</p> <p># <u>1</u> equation: $2x^2 + 7x - 15 = 0$</p> <p>Solve: $a=2$ $b=7$ $c=-15$ $x = \frac{-7 \pm \sqrt{7^2 - 4(2)(-15)}}{2(2)}$ $x = \frac{-7 \pm \sqrt{169}}{4}$ $x = \frac{-7+13}{4}$ or $x = \frac{-7-13}{4}$</p> <p>Solution(s): $x = \frac{3}{2}$ or $x = -5$</p> <p>✓ Verify that your answer(s) are solution(s) $2(\frac{3}{2})^2 + 7(\frac{3}{2}) - 15 = 0$ $2(-5)^2 + 7(-5) - 15 = 0$ $2(\frac{9}{4})$ $50 - 35 - 15 = 0$ $\frac{9}{2} + \frac{21}{2} - 15 = 0$ $0 = 0$ ✓</p>
--	---

5.20 Solving Quadratic Equations – Choosing the Best Method: Part II

#1 – 5 (continued): Four equations and one situation are given. Solve one by the *square root property*, one by *factoring*, one by *completing the square*, one using the *quadratic formula*, and one by *graphing*. Express your answers in simplest radical form. *Verify your answer*

Solve by: **Graphing**

5 equation: $h(t) = 76t^2 + 24t + 4755$

Solution(s): $t = 18.005$ seconds

✓ Verify that your answer(s) are solution(s)

$$h(18.005) = 76(18.005)^2 + 24(18.005) + 4755$$

$$0 \approx 0.2396 \text{ *}$$

very close, but not exact.

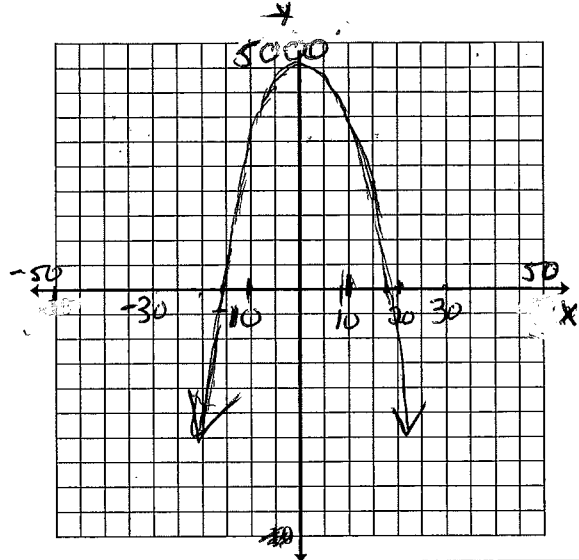

6. a) Solve $\sqrt{(x-4)^2} = \sqrt{9}$

$$|x-4| = 3$$

$$x = 4 \pm 3$$

$x = 7 \text{ or } x = 1$

b) Sketch the graphs of $y = (x-4)^2$ and $y = 9$.

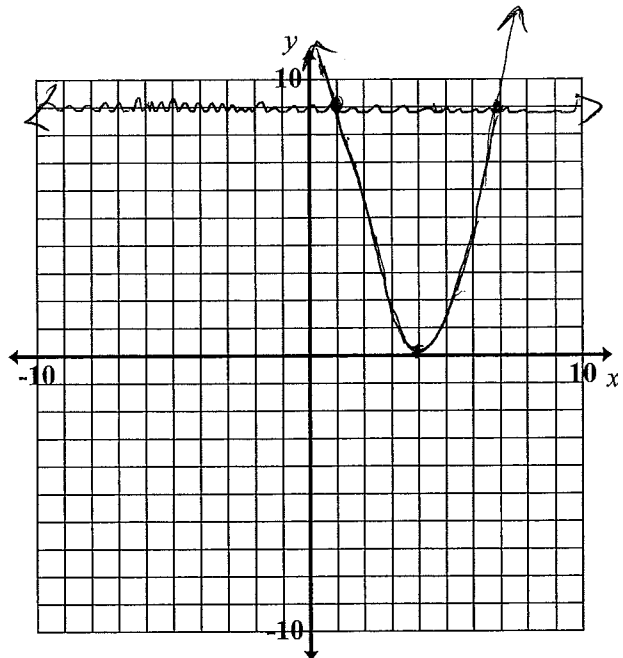

c) Describe the connection between the solution in part a) and the graph in part b).

The intersection points of the 2 graphs in part (b) are the solutions for x in part (a).

5.20 Solving Quadratic Equations – Choosing the Best Method: Part II

7. A hose used by the fire department shoots water out in a parabolic arc. Let x be the horizontal distance from the hose's nozzle, and y be the corresponding height of the stream of water, both in feet. The quadratic function is $y = -0.016x^2 + 0.5x + 4.5$.

a) Explain the meaning in the context of the situation of the 4.5 that appears in the equation.

The 4.5 feet is how far the hose's nozzle is above the ground where the water begins to shoot out.



b) What is the horizontal distance from the nozzle to where the stream hits the ground?

38.55 feet

c) Will the stream go over a 6-foot high fence that is located 28 feet from the nozzle? Explain your reasoning.

No, At 27.89 ft from the nozzle, the stream would hit the top of the 6-foot fence. However, at the 28 ft distance, the water height is lower, reaching only 5.96 feet high.

8. The graph of $y = x^2 - 400$ is shown at right. Notice that no coordinates appear in the diagram. Without using your graphing calculator, figure out the actual window that was used for this graph. Find the high and low values for both the x - and y -axis. After you get your answer check it on your calculator.

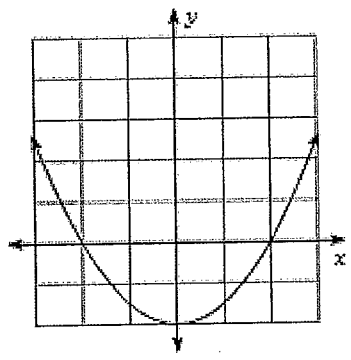

Xmin: -30

Xmax: 30

Ymin: -400

Ymax: 1000

Section 5.20

5.20 Solving Quadratic Equations – Choosing the Best Method: Part II

This page intentionally left blank

5.3A Number and Type of Solutions: Part I

1. What is the discriminant? What does it do?

In the quadratic formula, $x = \frac{-b \pm \sqrt{b^2 - 4ac}}{2a}$, the discriminant is the value of the expression $b^2 - 4ac$ that is UNDER the radical.

This number is used to determine the number and type of solutions of a quadratic equation.

#2 - 9: Find the discriminant, the number of solutions and the type of solutions for each equation.

2. $x^2 + 6x + 10 = 0$

$$\begin{aligned} b^2 - 4ac &= (6)^2 - 4(1)(10) \\ &= 36 - 40 \\ &= -4 \end{aligned}$$

discriminant: -4

number of solutions: 2

type of solutions: imaginary

3. $3x^2 + 2x = 1$

$$\begin{aligned} 3x^2 + 2x - 1 &= 0 \\ b^2 - 4ac &= (2)^2 - 4(3)(-1) \\ &= 4 + 12 \\ &= 16 \end{aligned}$$

discriminant: 16

number of solutions: 2

type of solutions: real, rational

4. $0 = x^2 - 4x + 4$

$$\begin{aligned} b^2 - 4ac &= (-4)^2 - 4(1)(4) \\ &= 16 - 16 \\ &= 0 \end{aligned}$$

discriminant: 0

number of solutions: 1

type of solutions: real, rational

5. $12x^2 = 11x + 2$

$$\begin{aligned} 12x^2 - 11x - 2 &= 0 \\ b^2 - 4ac &= (-11)^2 - 4(12)(-2) \\ &= 121 + 96 \\ &= 217 \end{aligned}$$

discriminant: 217

number of solutions: 2

type of solutions: real, irrational

5.3A Number and Type of Solutions: Part I

#2 - 9 (continued): Find the discriminant, the number of solutions and the type of solutions for each equation.

6. $8x+1=-16x^2$

$16x^2+8x+1=0$

$$b^2-4ac = (8)^2 - 4(16)(1)$$

$$= 64 - 64$$

$$= 0$$

discriminant: 0
 number of solutions: 1
 type of solutions: real, rational

7. $7x^2+16x+11=0$

$$b^2-4ac = (16)^2 - 4(7)(11)$$

$$= 256 - 308$$

$$= -52$$

discriminant: -52
 number of solutions: 2
 type of solutions: imaginary

8. $5x^2-11x+6=0$

$$b^2-4ac = (-11)^2 - 4(5)(6)$$

$$= 121 - 120$$

$$= 1$$

discriminant: 1
 number of solutions: 2
 type of solutions: real, rational

9. $0=4x^2+5x+2$

$$b^2-4ac = (5)^2 - 4(4)(2)$$

$$= 25 - 32$$

$$= -7$$

discriminant: -7
 number of solutions: 2
 type of solutions: imaginary

10. On a quiz, Brittani used the discriminant to find the number and type of solutions. Find her mistake and find the correct solution.

$$0 = x^2 - 6x + 5$$

$$b^2 - 4ac$$

$$-6^2 - 4(1)(5)$$

$$-36 - 20$$

discriminant: -56
 solutions: 2 imaginary solutions

-6 must be in parentheses

$$(-6)^2 - 4(1)(5)$$

$$36 - 20$$

discriminant = 16
 solutions: 2 real, rational

5.3A Number and Type of Solutions: Part I

11. Emma and Brandon own a factory that produces bike helmets. Their accountant says that their profit per year is given by the function $P(x) = 0.003x^2 + 12x + 27760$, where x represents the number of helmets produced. Their goal is to make a profit of \$40,000 this year.

a) Write the equation that would represent a \$40,000 profit.

$$40,000 = 0.003x^2 + 12x + 27760$$

b) Write the equation in standard form.

$$0.003x^2 + 12x - 12240 = 0$$

c) Find the discriminant.

$$b^2 - 4ac = (12)^2 - 4(0.003)(-12240)$$

$$= 144 + 146.88$$

$$= 290.88$$

d) Based on the discriminant, is the profit possible? Explain your thinking.

Yes, the discriminant is > 0 which yields 2 real solutions; the positive root would pertain to this story.

12. Marty is outside his apartment building. He needs to give Yolanda her cell phone but he does not have time to run upstairs to the third floor to give it to her. He throws it straight up with a vertical velocity of 55 feet/second. Will the phone reach her if she is 36 feet up?

(Hint: The equation for the height is given by $y = -16t^2 + 55t + 4$)

$$-16t^2 + 55t + 4 = 36$$

$$-16t^2 + 55t - 32 = 0$$

$$\text{discriminant} = (55)^2 - 4(-16)(-32)$$

$$= 3025 - 2048$$

$$d = 977$$

Yes, the discriminant > 0 yields 2 real solutions.

13. Bryson owns a business that manufactures and sells tires. The revenue from selling the tires in the month of July is given by the function $R(x) = x(200 - 4x)$ where x is the number of tires sold. Can Bryson's business generate revenue, R , of \$20,000 in the month of July?

$$200x - 4x^2 = 20,000$$

$$0 = 4x^2 - 200x + 20,000$$

$$\text{"d" for discriminant} = (-200)^2 - 4(4)(20,000)$$

$$= 40000 - 320,000$$

$$d = -280,000$$

No, since discriminant < 0 , there are no real solutions.

Section 5.3A

5.3A *Number and Type of Solutions: Part I*

This page intentionally left blank

5.3B Number and Type of Solutions: Part II

1. $y = x^2 - 2x - 8$

a) What is the discriminant?

$$b^2 - 4(ac) = (-2)^2 - 4(1)(-8)$$

$$= 4 + 32$$

$$= \boxed{36}$$

b) Number of solutions? 2

c) Type of solutions? real, rational

d) What are the zeros (roots)? $x = -2$

*Factor or use the graph $x = 4$

$$(x + 2)(x - 4) = 0$$

e) Graph the equation.

x	-2	-1	0	1	2	4
y	0	-5	-8	-9	-8	0

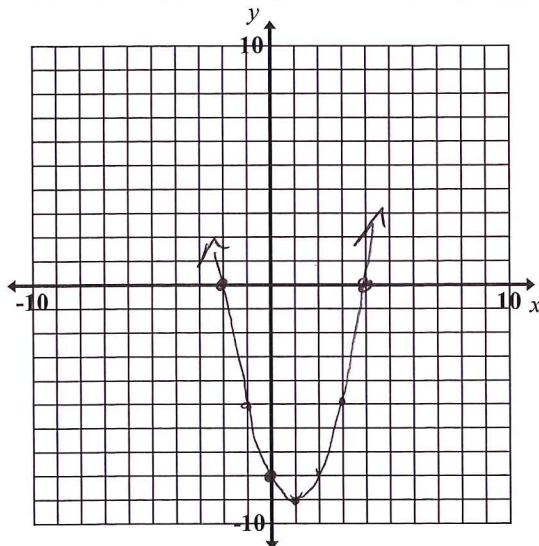

f) What is the vertex? $(1, -9)$

g) Is the vertex a minimum or maximum?

h) What is the y-intercept? $(0, -8)$

i) What is the domain? all real numbers

j) What is the range? $y \geq -9$

2. $y = 9 - x^2$

a) What is the discriminant? $-x^2 + 9 = 0$

$$b^2 - 4ac = (0)^2 - 4(-1)(9)$$

$$= 0 + 36$$

$$= \boxed{36}$$

b) Number of solutions? 2

c) Type of solutions? real rational

d) What are the zeros (roots)? $-1(x^2 - 9) = 0$

*Factor or use the graph $x^2 - 9 = 0$

$$x = -3, x = 3 \quad (x + 3)(x - 3) = 0$$

e) Graph the equation.

x	-3	-2	-1	0	2	3
y	0	5	8	9	5	0

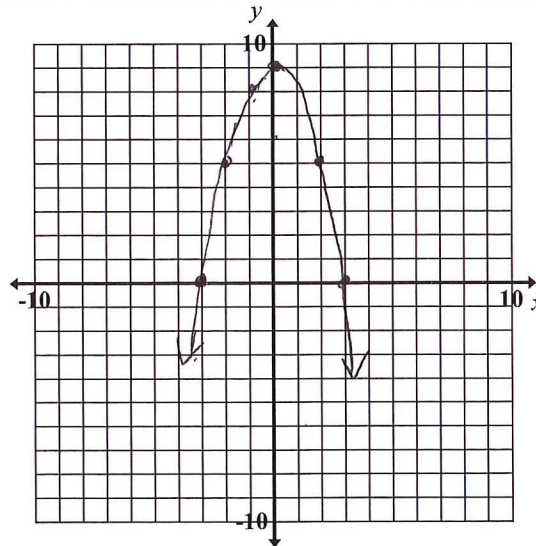

f) What is the vertex? $(0, 9)$

g) Is the vertex a minimum or maximum?

h) What is the y-intercept? $(0, 9)$

i) What is the domain? all reals

j) What is the range? $y \leq 9$

5.3B Number and Type of Solutions: Part II

3. Which equation could model the graph to the right?

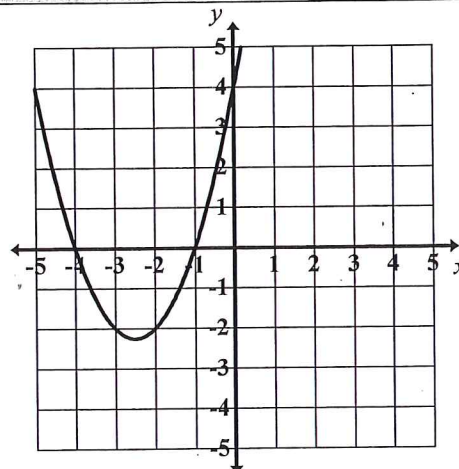

[A] $y = -(x-4)(x-1)$

[B] $y = -(x+4)(x+1)$

[C] $y = (x-4)(x-1)$

[D] $y = (x+4)(x+1)$ $x = -4$ or $x = -1$
 $0 = (x+4)(x+1)$

#4 – 6: Find the discriminant of each equation and then state the number and type of solutions.

4. $x^2 + 6x = -2$ $(6)^2 - 4(1)(2)$
 $x^2 + 6x + 2 = 0$ $36 - 8$
 discriminant: 28
 number of solutions: 2
 real or imaginary: real, irr
5. $2x^2 - 8x = -8$ $(-4)^2 - 4(1)(4)$
 $x^2 - 4x + 4 = 0$ $16 - 16$
 discriminant: 0
 number of solutions: 1
 real or imaginary: real, rational
6. $5x^2 - 13x + 9 = 0$ $(-13)^2 - 4(5)(9)$
 $169 - 180$
 discriminant: -11
 number of solutions: 2
 real or imaginary: imaginary

7. Label each graph below as having a **positive**, **negative**, or **zero** discriminant.

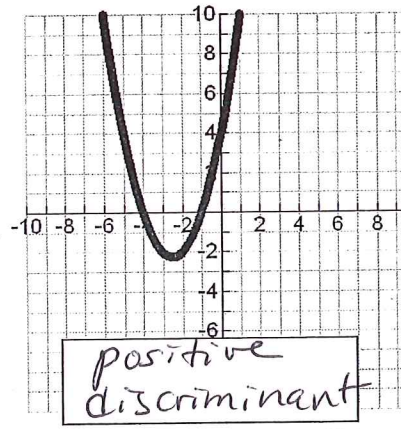
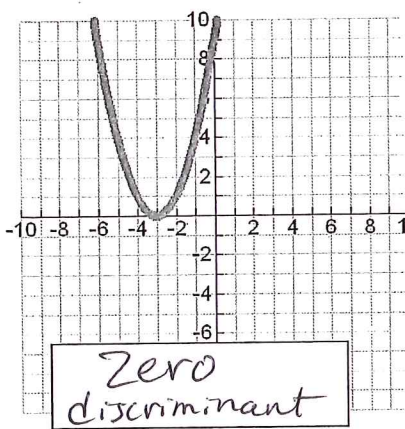
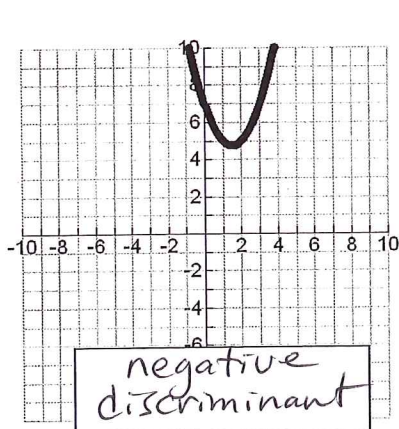

8. What type of discriminant does the graph have? How many solutions does the graph have? Write a possible equation to model the graph pictured to the right.

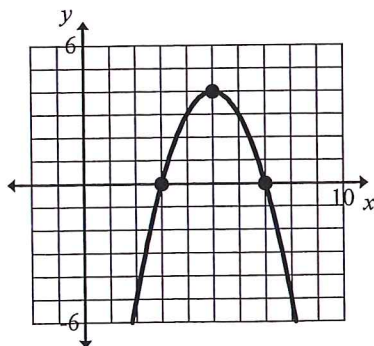

Discriminant a positive perfect square number

Type and number of solutions 2 real rational

A possible equation $y = -(x-3)(x-7)$
 or
 $y = -(x^2 - 10x + 21)$
 $y = -x^2 + 10x - 21$

Section 5.3B

5.4A Graphing Quadratic Inequalities

#1 – 3: Determine whether each of the given points is a solution to the given quadratic inequality.

1. $y \geq x^2 - 3x + 3$

a) (0,0)

$0 \geq (0)^2 - 3(0) + 3$
 $0 \geq 3$ False

NOT a SOLN

b) (1,1)

$1 \geq (1)^2 - 3(1) + 3$
 $1 \geq 1$ True

SOLN

2. $y < -\frac{1}{2}x^2 - x + 6$

a) (0,0)

$0 < -\frac{1}{2}(0)^2 - 0 + 6$
 $0 < 6$ True

SOLN

b) (3,3)

$3 < -\frac{1}{2}(3)^2 - (3) + 6$
 $< -\frac{9}{2} - 3 + 6$
 $3 < -1\frac{1}{2}$ False

NOT SOLN

3. $y > 2x^2 - x + 4$

a) (0,0)

$0 > 2(0)^2 - 0 + 4$
 $0 > 4$ False

NOT SOLN

b) (1,5)

$5 > 2(1)^2 - (1) + 4$
 $5 > 5$ False

NOT SOLN

#4 – 6: For each inequality and graph (the points plotted are points that exist on the boundary)...

- determine whether the boundary is included as a solution (solid) or not included as part of the solution (dashed).
 - use a test point to determine the solution region.
- Graph the solution to each inequality.

4. $y \leq x^2 - 4$

use (0,0)
 $0 \leq -4$ False

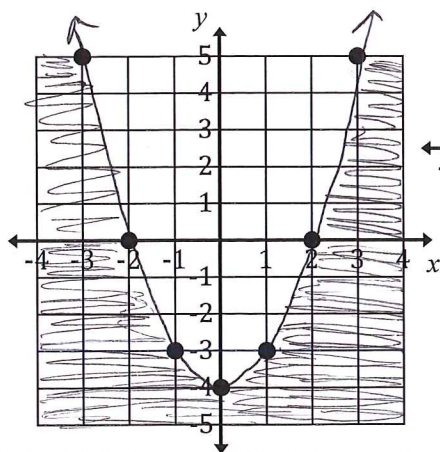

5. $y \geq -2x^2 + 4x - 3$

use (0,0)
 $0 \geq -3$ True

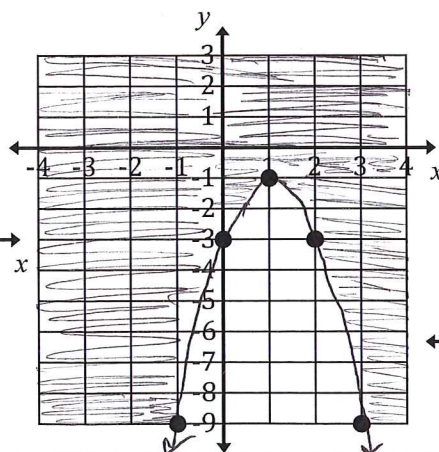

6. $y > -5x^2 - 20x + 6$

use (0,0)
 $0 > 6$ False

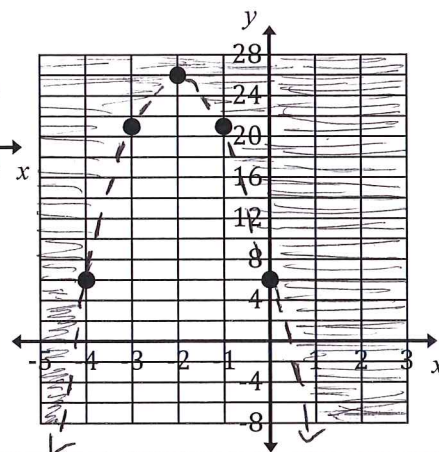

5.4A Graphing Quadratic Inequalities

#7 – 9: Fill in the blank with the appropriate inequality sign.

7. y $\boxed{<}$ $\frac{1}{4}x^2 - 1x - \frac{5}{4}$ 8. y $\boxed{\leq}$ $-\frac{1}{4}x^2 - 1x - \frac{5}{4}$ 9. y $\boxed{>}$ $5x^2 + 4$

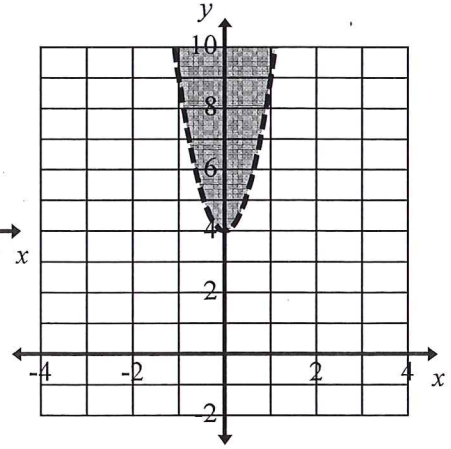
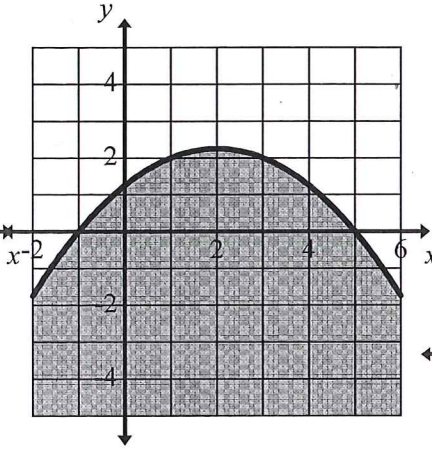
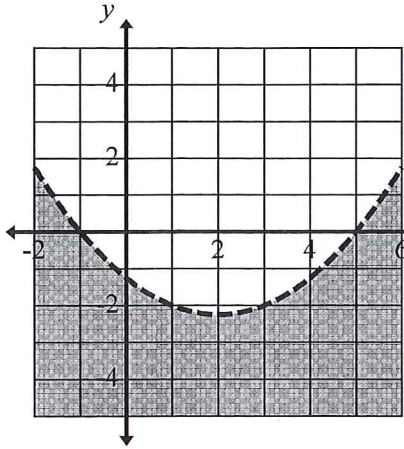

#10 – 15: Match the inequality with its graph.

C 10. $y \geq -x^2 + 4x - 3$ A 11. $y \leq -x^2 - 4x - 3$ F 12. $y \leq x^2 + 2x - 3$
E 13. $y < x^2 - 4x + 3$ B 14. $y > -x^2 + 4x - 3$ D 15. $y > x^2 - 2x - 3$

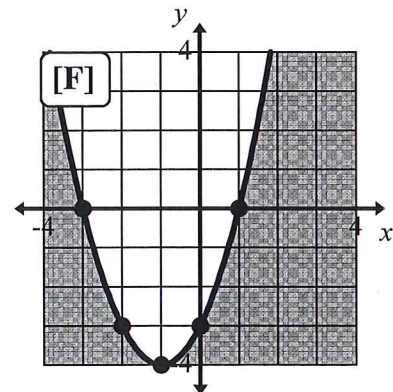
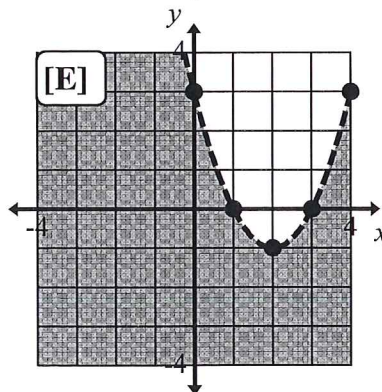
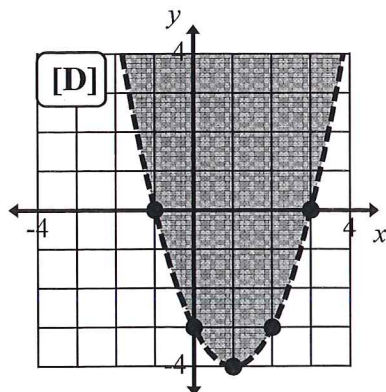
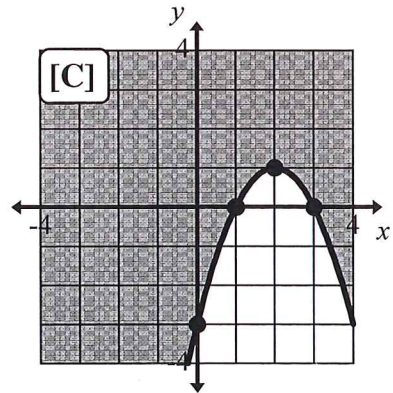
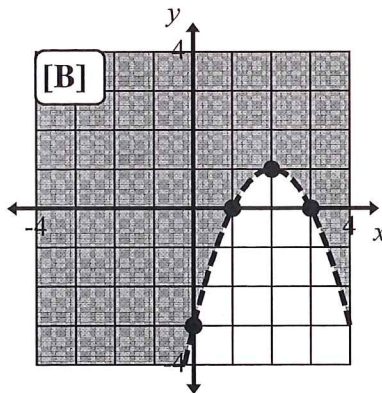
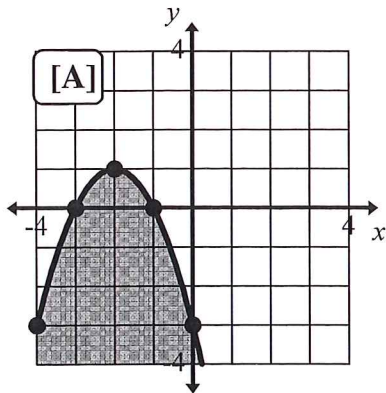

5.4A Graphing Quadratic Inequalities

#16 – 23: Draw the graph of each quadratic inequality. When graphing the boundary, consider the various forms of a quadratic and the significant features that are identified from each form.

16. $y < x^2 - 2x - 1$

$$\begin{aligned} x^2 - 2x &= 1 + 1 \\ x^2 - 2x + 1 &= 2 \\ \sqrt{(x-1)^2} &= \sqrt{2} \\ |x-1| &= \sqrt{2} \\ x-1 &= \pm\sqrt{2} \\ x &= 1 \pm \sqrt{2} \approx -0.41, 2.41 \end{aligned}$$

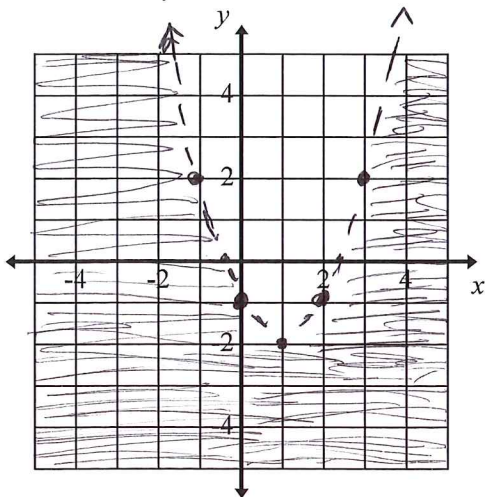

17. $y \geq x^2 - 9$

$$\begin{aligned} (x+3)(x-3) \\ x = -3, x = 3 \end{aligned}$$

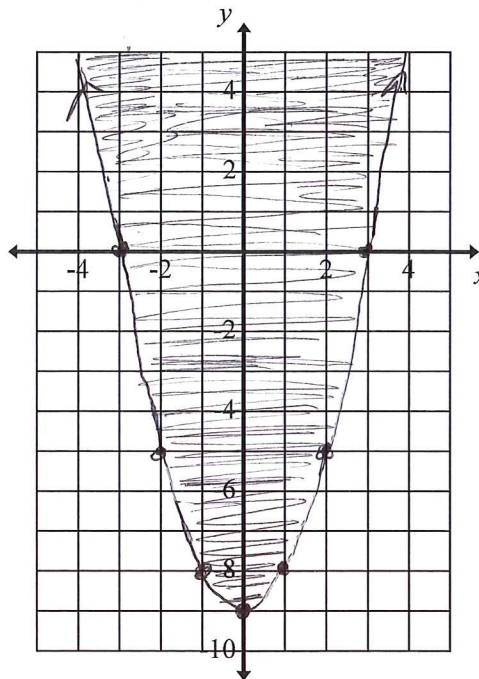

18. $y > -x^2 + 7x - 12$

$$\begin{aligned} 0 &= -1(x^2 - 7x + 12) \\ 0 &= -1(x-3)(x-4) \\ x &= 3, x = 4 \end{aligned}$$

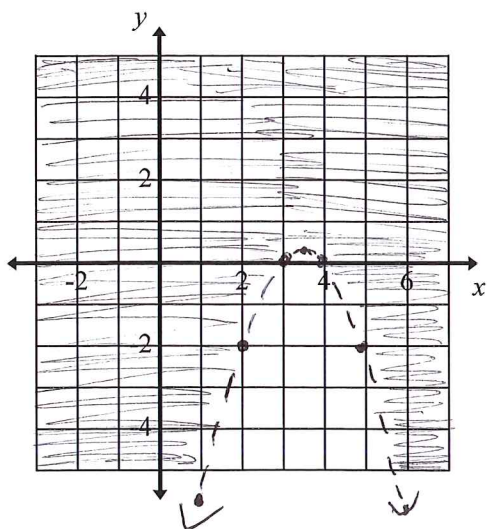

19. $y \leq -2x^2 - 7x + 1$

$$a = -2 \quad b = -7 \quad c = 1$$

$$\begin{aligned} x &= \frac{7 \pm \sqrt{(-7)^2 - 4(-2)(1)}}{2(-2)} \\ x &= \frac{7 \pm \sqrt{57}}{-4} \\ x &= \frac{-7 \pm \sqrt{57}}{4} \approx 0.14, -3.64 \end{aligned}$$

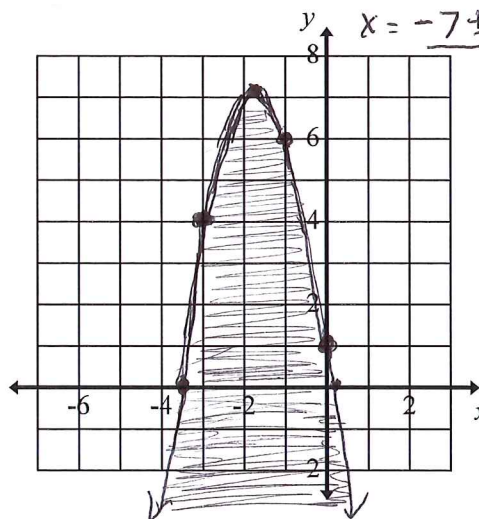

5.4A Graphing Quadratic Inequalities

#16 – 23 (continued): Draw the graph of each quadratic inequality. When graphing the boundary, consider the various forms of a quadratic and the significant features that are identified from each form.

20. $y \leq -x^2 - 5x + 1$
 $a = -1$
 $b = -5$
 $c = 1$

$x = \frac{5 \pm \sqrt{(-5)^2 - 4(-1)(1)}}{2(-1)}$
 $x = \frac{5 \pm \sqrt{29}}{-2}$
 $\rightarrow -5.19$
 $\rightarrow 0.19$

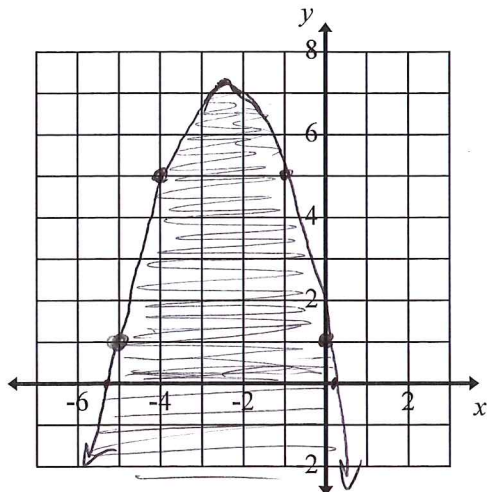

21. $y > \frac{1}{2}(x+6)^2 - 3$

$\frac{1}{2}(x+6)^2 - 3 = 0$
 $\frac{1}{2}(x+6)^2 = 3$
 $\sqrt{\frac{1}{2}(x+6)^2} = \sqrt{6}$
 $|x+6| = \sqrt{6}$
 $x = -6 \pm \sqrt{6}$
 $\rightarrow -3.55$
 $\rightarrow -8.44$

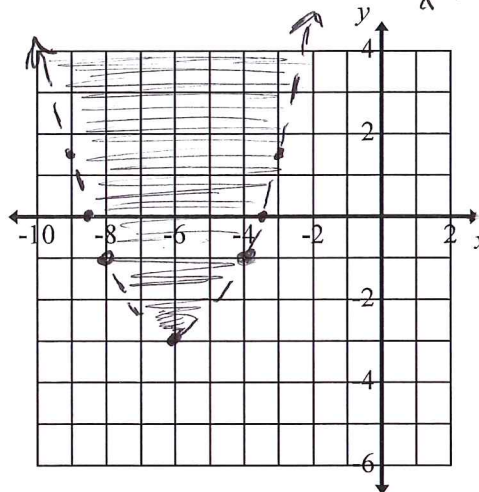

22. $y > \frac{1}{2}(x+1)(x-5)$
 $x = -1, x = 5$

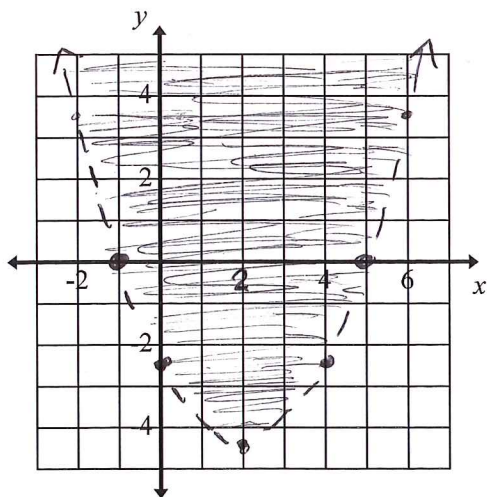

23. $y \leq -2(x+1)^2 + 6$

$-2(x+1)^2 + 6 = 0$
 $-2(x+1)^2 = -6$
 $\sqrt{(x+1)^2} = \sqrt{3}$
 $|x+1| = \sqrt{3}$
 $x = -1 \pm \sqrt{3}$
 $\rightarrow 0.73$
 $\rightarrow -2.73$

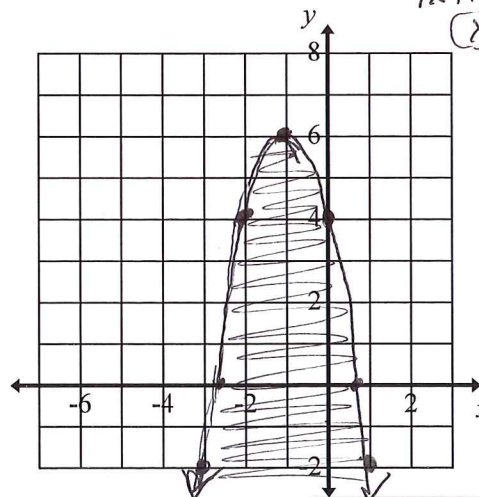

Section 5.4A

5.4B Solving Quadratic Inequalities

1. Graph $f(x) = x^2 + 2x - 8$

a) On what interval(s) is $x^2 + 2x - 8 > 0$?

$$(x+4)(x-2) = 0$$

$$x = -4, x = 2$$

When $x < -4$ or $x > 2$

b) On what interval(s) is $x^2 + 2x - 8 < 0$?

$$-4 < x < 2$$

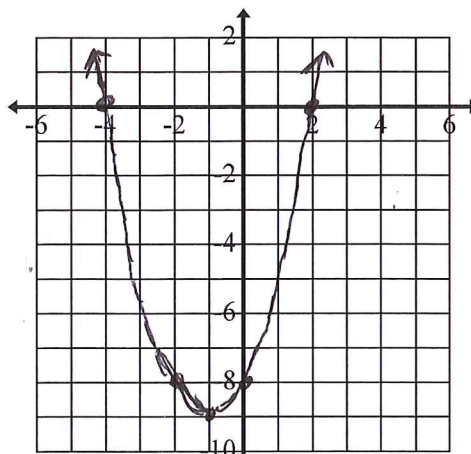

2. Graph $f(x) = -x^2 - x + 6$

a) On what interval(s) is $-x^2 - x + 6 > 0$?

$$-(x^2 + x - 6) = 0$$

$$(x+3)(x-2) = 0$$

$$x = -3 \text{ or } x = 2$$

$$-3 < x < 2$$

b) On what interval(s) is $-x^2 - x + 6 < 0$?

$$x < -3 \text{ or } x > 2$$

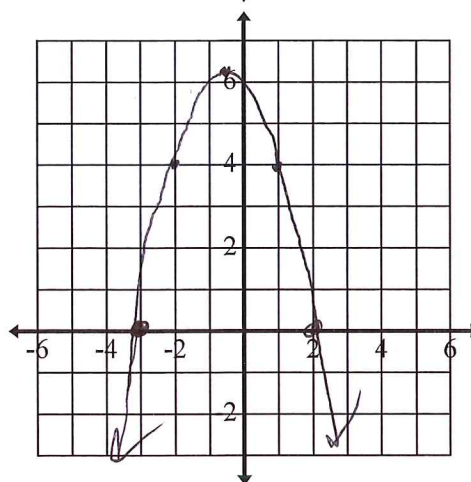

3. Draw a quadratic function that is:

- Positive when $x < -1$ and $x > 5$
- Negative when $-1 < x < 5$

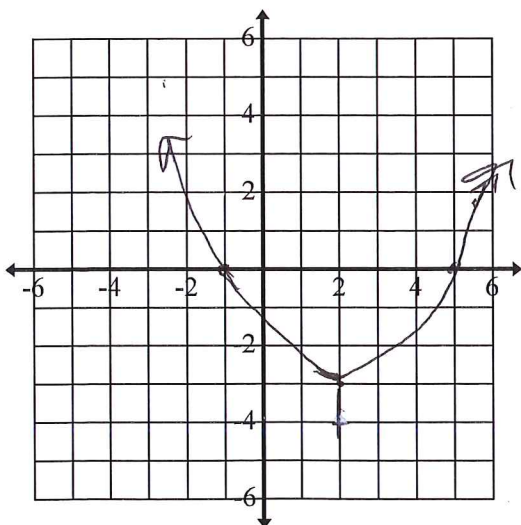

4. Draw a quadratic function that is:

- Positive when $-4 < x < 0$
- Negative when $x < -4$ and $x > 0$

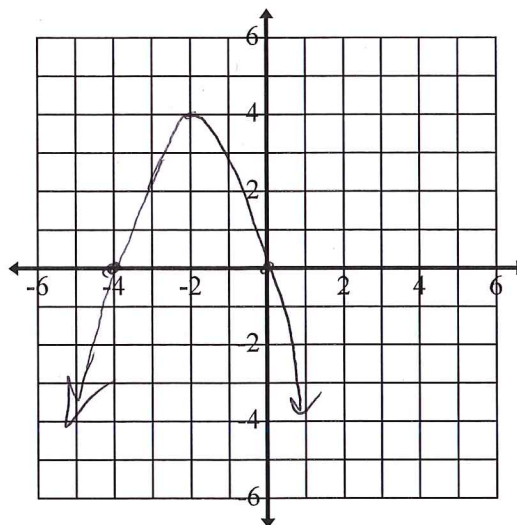

5.4B Solving Quadratic Inequalities

#5 - 12: Use a graph to find the solution for the following inequalities.

5. $x^2 - 25 > 0$ $x^2 = 25$ $x = \pm 5$

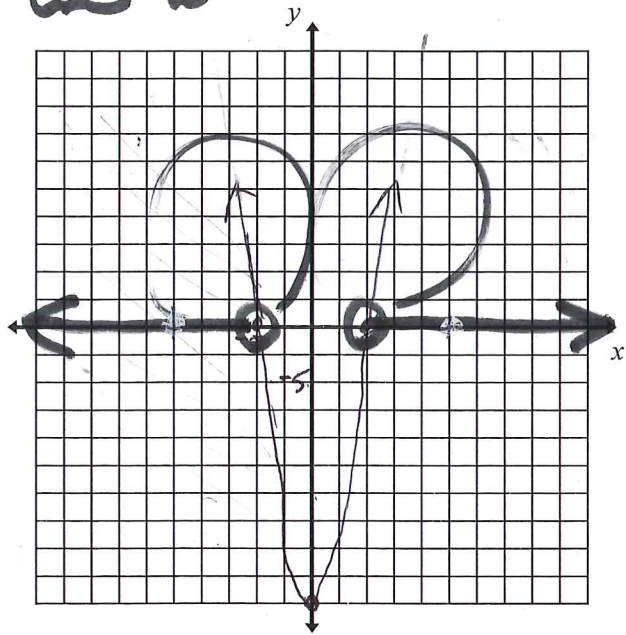

Solution: $x < -5$ or $x > 5$

6. $x^2 - 4x \geq 0$ $x(x-4) = 0$ $x=0$ $x=4$

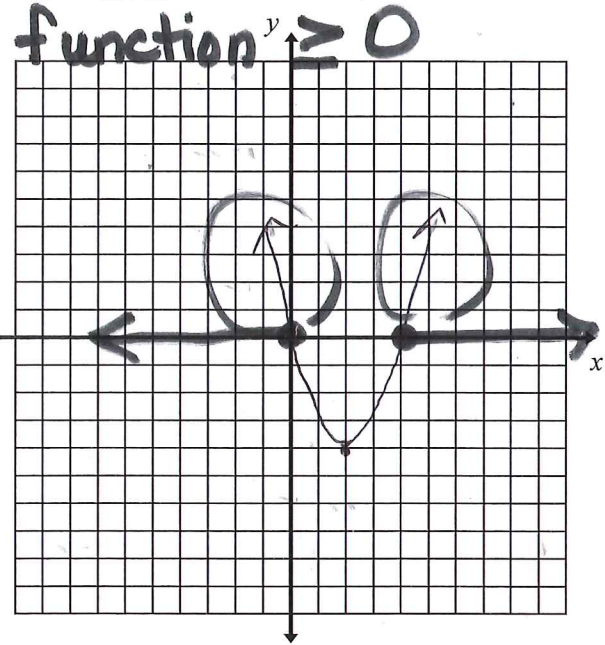

Solution: $x \leq 0$ or $x \geq 4$

7. $x^2 - 7x + 10 < 0$
 $(x-5)(x-2) = 0$
 $x=5, x=2$

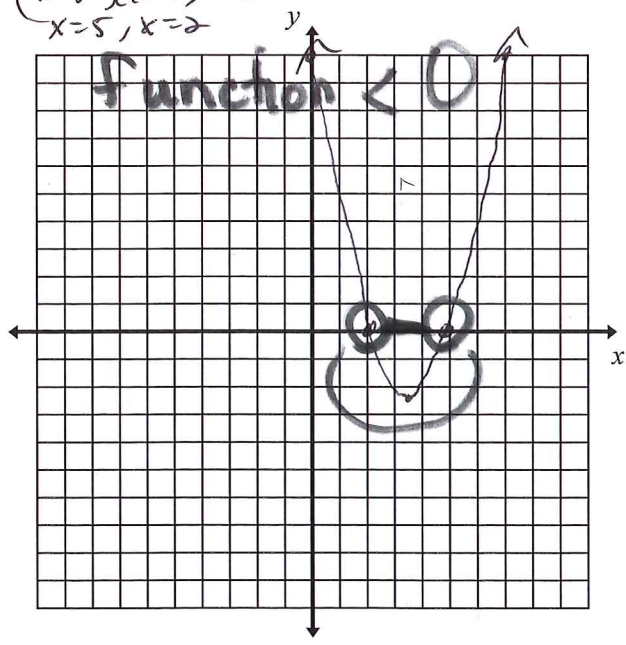

Solution: $2 < x < 5$

8. $x^2 - 5x - 12 \leq 0$
 $a=1$ $b=-5$ $c=-12$
 $x = \frac{5 \pm \sqrt{(-5)^2 - 4(1)(-12)}}{2(1)}$
 $x = \frac{5 \pm \sqrt{73}}{2}$

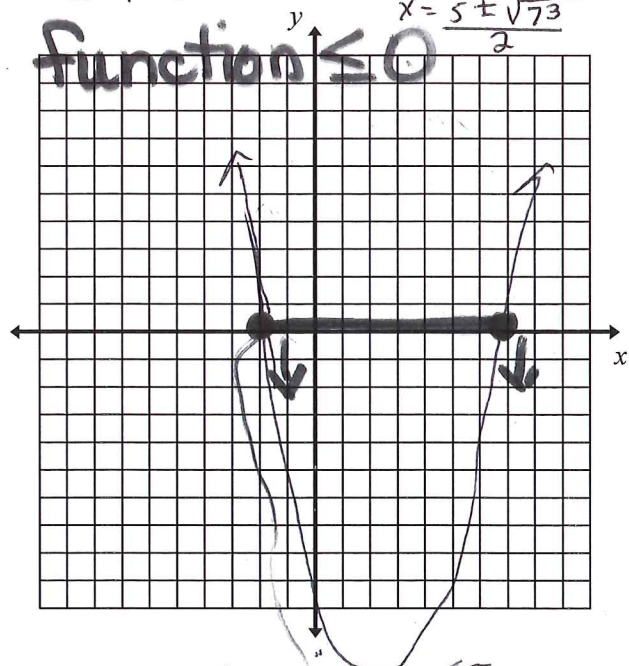

Solution: $\frac{5 - \sqrt{73}}{2} \leq x \leq \frac{5 + \sqrt{73}}{2}$

5.4B Solving Quadratic Inequalities

#5 - 12 (continued): Use a graph to find the solution for the following inequalities.

9. $x^2 > 8x + 20$ $x^2 - 8x - 20 = 0$
 $x^2 - 8x - 20 > 0$ $(x-10)(x+2) = 0$
 $x = 10$ $x = -2$

function values > 0

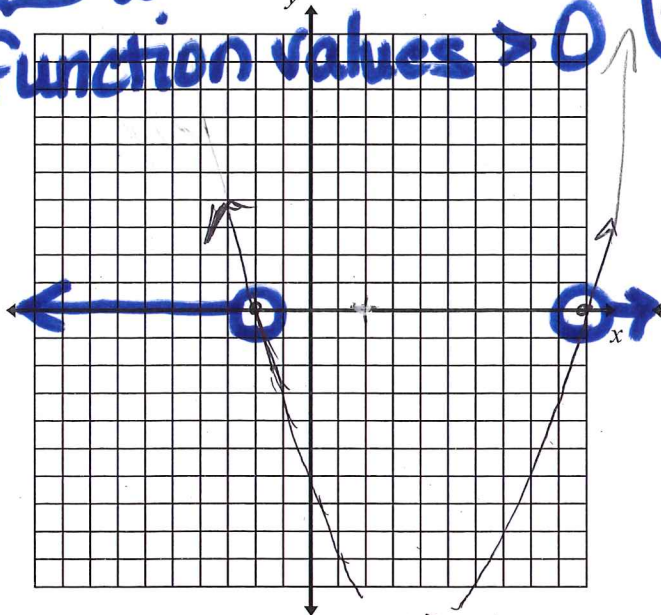

Solution: $x < -2$ or $x > 10$

10. $x^2 + 27 < 12x$ $x^2 - 12x + 27 < 0$
 $(x-9)(x-3) = 0$ $x = 9, x = 3$

function values < 0

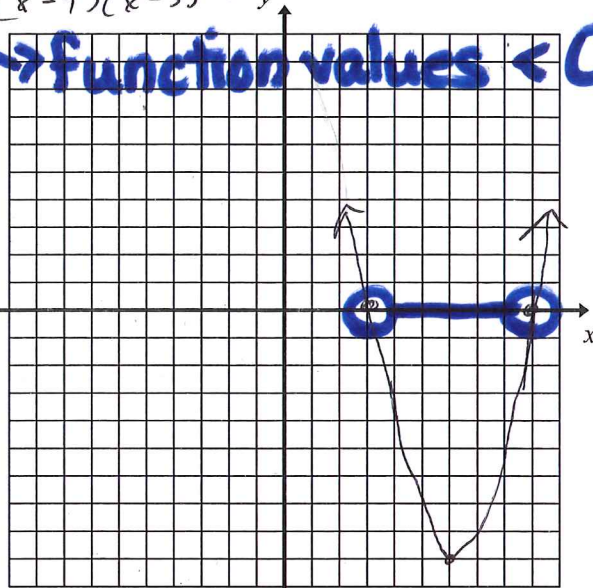

Solution: $3 < x < 9$

11. $2x^2 - 11x + 5 \geq 0$ $(2x-1)(x-5) = 0$
 $x = \frac{1}{2}, x = 5$

function values ≥ 0

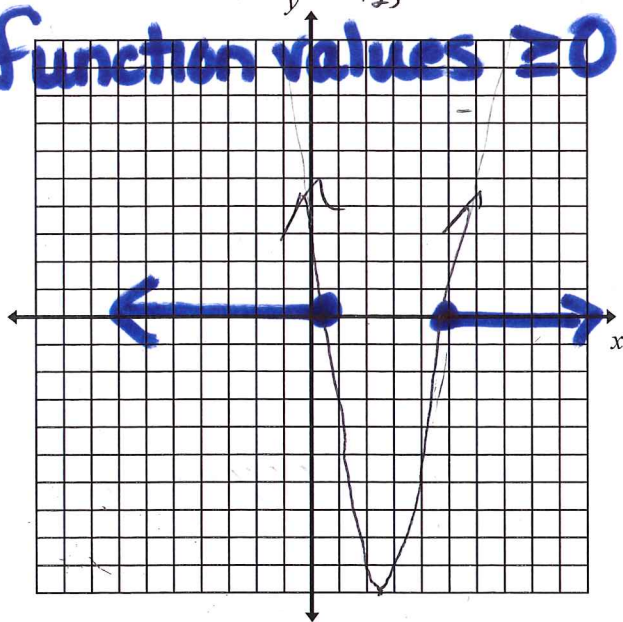

Solution: $x \leq \frac{1}{2}$ or $x \geq 5$

12. $3x^2 - 17x + 10 < 0$ $(3x-2)(x-5) = 0$
 $x = \frac{2}{3}$ or $x = 5$

function values < 0

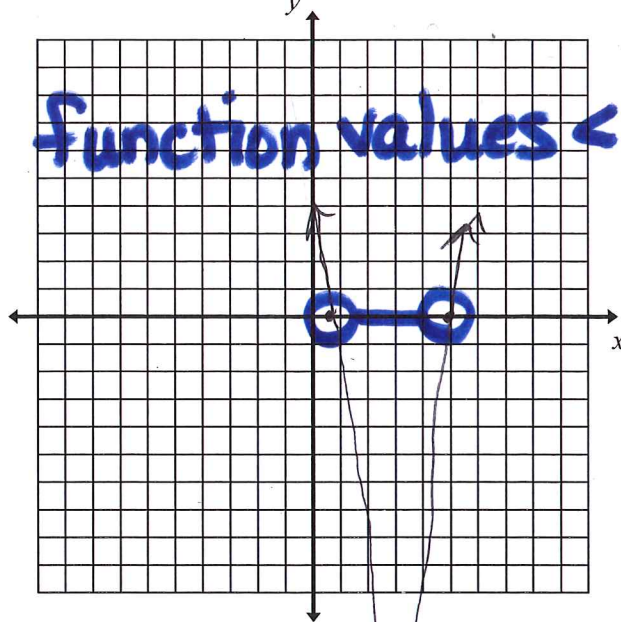

Solution: $\frac{2}{3} < x < 5$

5.4B Solving Quadratic Inequalities

#13 – 17: Use your graphing calculator to solve the following problems. Sketch the graph and label the x-intercepts and vertex.

13. The profit a coat manufacturer makes each day is modeled by the equation $P = -x^2 + 120x - 2000$, where P is the profit and x is the price for each coat sold. For what values of x does the company make a profit?

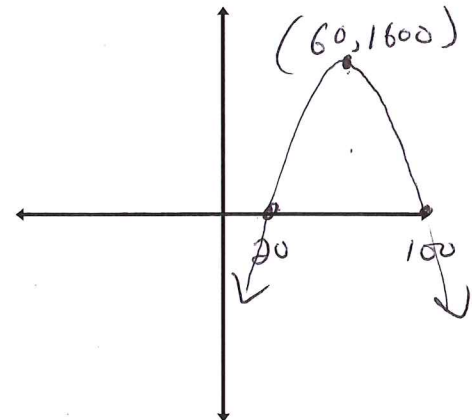

14. When a baseball is hit by a batter, the height of the ball, h , at time t , is determined by the equation $h(t) = -16t^2 + 64t + 4$. For which interval of time is the height of the ball greater than or equal to 52 feet?

$$-16t^2 + 64t + 4 = 52$$

$$-16t^2 + 64t - 48 = 0$$

$$t = 1 \text{ or } t = 3$$

$1 \leq t \leq 3$

seconds

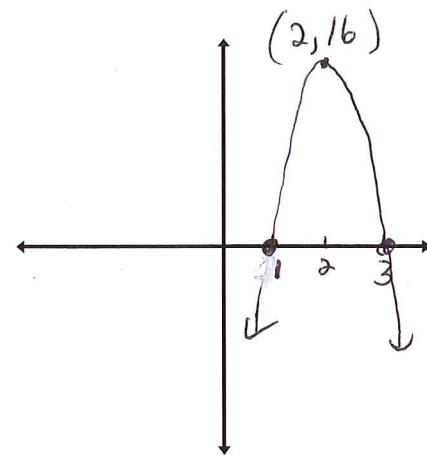

15. The path of a soccer ball kicked from the ground can be modeled by $y = -0.0540x^2 + 1.43x$ where x is the horizontal distance (in feet) from where the ball was kicked and y is the corresponding height (in feet).

- a) A soccer goal is 8 feet high. Write and solve an inequality to find at what values of x the ball is low enough to go into the goal.

$$-0.0540x^2 + 1.43x - 8 < 0$$

when $0 \leq x \leq 8.03$ and $x \geq 18.45$ ft

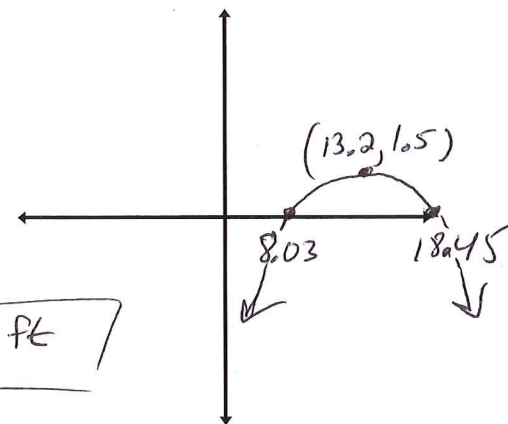

- b) A soccer player kicks the ball toward the goal from a distance of 15 feet away. No one is blocking the goal. Will the player score a goal? Explain your reasoning.

No! From 15 feet away, the height of the ball would be 9.3 ft. So the ball would go over the top of the net. Also, from the graph and algebraic solution inequalities above, 15 is not in the correct ranges.

5.4B Solving Quadratic Inequalities

#13 – 17 (continued): Use your graphing calculator to solve the following problems. Sketch the graph and label the x-intercepts and vertex.

16. A manilla rope used for rappelling down a cliff can safely support a weight W (in pounds) modeled by the inequality $W \leq 1480d^2$ where d is the rope's diameter (in inches). What diameter of rope would be needed to support a weight of at least 5920 pounds?

~~$d = -2$~~
 extraneous $d \geq 2$ inches
 $1480d^2 - 5920 \geq 0$

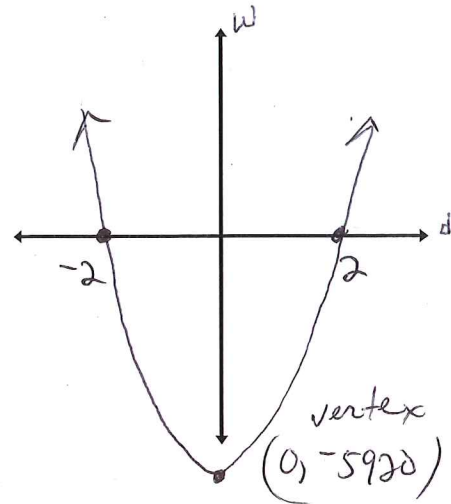

17. For a driver aged x years, a study found that the driver's reaction time v (in milliseconds) to a visual stimulus such as a traffic light can be modeled by $v = 0.005x^2 - 0.23x + 22$ when $16 \leq x \leq 70$. At what age does a driver's reaction time tend to be greater than 25 milliseconds?

$0.005x^2 - 0.23x + 22 > 25$
 $0.005x^2 - 0.23x - 3 > 0$
 given age restrictions above,
 driver's age should be $56.6 < x \leq 70$

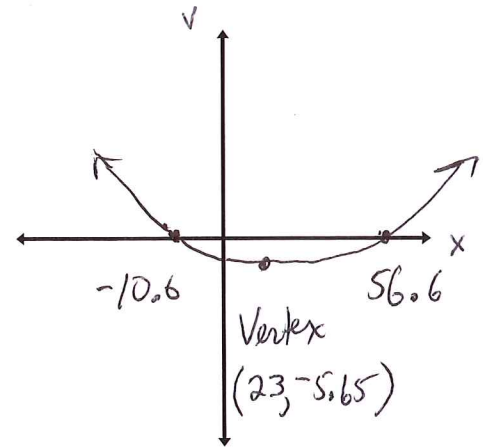

5.4B *Solving Quadratic Inequalities*

This page intentionally left blank

Section 5.4B

Unit 5 Review Materials

- Describe what you look for in determining which method is best to solve a quadratic equation:
 - Square Root: *No x-term, Ex: $x^2 = c$, or $a(x \pm h)^2 = c$*
 - Completing the Square: *If unfactorable and $a=1$ and b is even*
 - Factoring: *a, b, c are all integers and fairly small*
 - Quadratic Formula: *If unfactorable and a, b, c are larger numbers and/or decimals.*

- Choose the most efficient method for each equation. **You must select 3 equations for each method.** *
 - Place a circle around the letter of each equation you would solve using the square root method.
 - Place a square around the letter of each equation you would solve by completing the square.
 - Place a triangle around the letter of each equation you would solve by factoring.
 - The three equations with no mark would represent the equations you would solve using the quadratic formula.

* one possibility given below

$\triangle [A] 2x^2 + 5 = 41$	$\triangle [B] 3x^2 + 17x = -10$	$\square [C] x^2 + 20x = -104$
$\square [D] x^2 - 6x - 15 = 0$	$\square [E] x^2 + 4x = 12$	$\triangle [F] 8x^2 - 28x - 60 = 0$
$[G] 3x^2 + 6x + 2 = 0$	$[H] 6x^2 - 8x = -3$	$\triangle [I] 9x^2 + 12x + 4 = 0$
$\circ [J] -3(x-1)^2 = 36$	$\circ [K] 2(x-6)^2 - 45 = 53$	$[L] 5x^2 - 13x + 6 = 0$

- The letters you placed a circle around represent the equations you would solve using the square root method. Write one equation in each blank below (3 blanks, 3 equations). Solve each equation using the square root method to find the real or imaginary solutions:

a) $\circ A) 2x^2 + 5 = 41$
 $2x^2 = 36$
 $\sqrt{x^2} = \sqrt{18}$
 $|x| = \sqrt{9 \cdot 2}$
 $x = \pm 3\sqrt{2}$

b) $\circ J) -3(x-1)^2 = 36$
 $\sqrt{(x-1)^2} = \sqrt{-12}$
 $|x-1| = 2i\sqrt{3}$
 $x = 1 \pm 2i\sqrt{3}$

c) $\circ K) 2(x-6)^2 - 45 = 53$
 $\sqrt{2(x-6)^2} = \sqrt{98}$
 $\sqrt{(x-6)^2} = \sqrt{49}$
 $|x-6| = 7$
 $x = 6 \pm 7$
 $x = 13 \text{ or } x = -1$

- The letters you placed a square around represent the equations you would solve by completing the square. Write one equation in each blank below (3 blanks, 3 equations). Solve each equation by completing the square to find the real or imaginary solutions:

a) $\square C) x^2 + 20x = -104$
 $x^2 + 20x + 100 = -104 + 100$
 $\sqrt{(x+10)^2} = \sqrt{-4}$
 $|x+10| = 2i$
 $x = -10 \pm 2i$

b) $\square D) x^2 - 6x - 15 = 0$
 $x^2 - 6x = 15$
 $x^2 - 6x + 9 = 15 + 9$
 $\sqrt{(x-3)^2} = \sqrt{24}$
 $|x-3| = 2\sqrt{6}$
 $x = 3 \pm 2\sqrt{6}$

c) $\square E) x^2 + 4x = 12$
 $x^2 + 4x + 4 = 12 + 4$
 $\sqrt{(x+2)^2} = \sqrt{16}$
 $|x+2| = 4$
 $x = -2 \pm 4$
 $x = 2 \text{ or } x = -6$

Unit 5 Review Materials

5. The letters you placed a triangle around represent the equations you would solve by factoring. Write one equation in each blank below (3 blanks, 3 equations). Solve each equation by factoring to find the real or imaginary solutions:

a) B) $3x^2 + 17x = -10$
 $3x^2 + 17x + 10 = 0$
 $(3x + 2)(x + 5) = 0$
 $x = -\frac{2}{3}$ or $x = -5$

b) F) $8x^2 - 28x - 60 = 0$
 $2x^2 - 7x - 15 = 0$
 $(2x + 3)(x - 5) = 0$
 $x = -\frac{3}{2}$ or $x = 5$

c) I) $9x^2 + 12x + 4 = 0$
 $(3x + 2)(3x + 2) = 0$
 $x = -\frac{2}{3}$

6. ^{with no mark around them you would solve using the Quad. formula.} The letters you placed a triangle around represent the equations you would solve by factoring. Write one equation in each blank below (3 blanks, 3 equations). Solve each equation using the quadratic formula to find the real or imaginary solutions:

a) G) $3x^2 + 6x + 2 = 0$
 $a = 3, b = 6, c = 2$
 $x = \frac{-6 \pm \sqrt{(6)^2 - 4(3)(2)}}{2(3)}$
 $x = \frac{-6 \pm \sqrt{12}}{6} = \frac{-6 \pm 2\sqrt{3}}{6}$
 $x = \frac{-3 \pm \sqrt{3}}{3}$

b) H) $6x^2 - 8x = -3$
 $6x^2 - 8x + 3 = 0$
 $a = 6, b = -8, c = 3$
 $x = \frac{8 \pm \sqrt{(-8)^2 - 4(6)(3)}}{2(6)}$
 $x = \frac{8 \pm \sqrt{-8}}{12} = \frac{8 \pm 2i\sqrt{2}}{12}$
 $x = \frac{4 \pm i\sqrt{2}}{6}$

c) L) $5x^2 - 13x + 6 = 0$
 $a = 5, b = -13, c = 6$
 $x = \frac{13 \pm \sqrt{(-13)^2 - 4(5)(6)}}{2(5)}$
 $x = \frac{13 \pm \sqrt{49}}{10} = \frac{13 \pm 7}{10}$
 $x = 2$, or $x = \frac{3}{5}$

7. Simplify.

a) $\frac{-4 \pm \sqrt{50}}{12}$
 $\frac{-4 \pm \sqrt{25 \cdot 2}}{12}$
 $\frac{-4 \pm 5\sqrt{2}}{12}$

b) $\frac{3 \pm \sqrt{81}}{12}$
 $\frac{3 \pm 9}{12} = \frac{12}{12}$ or $\frac{-6}{12}$
 1 or $-\frac{1}{2}$

c) $\frac{-6 \pm \sqrt{-45}}{3}$
 $\frac{-6 \pm \sqrt{9 \cdot 5 \cdot (-1)}}{3}$
 $\frac{-6 \pm 3i\sqrt{5}}{3}$
 $-2 \pm i\sqrt{5}$

d) $\frac{7 \pm \sqrt{-12}}{14}$
 $\frac{7 \pm \sqrt{4 \cdot 3 \cdot (-1)}}{14}$
 $\frac{7 \pm 2i\sqrt{3}}{14}$

8. A ball is thrown off of a rooftop 200 feet high with an initial velocity of 40 feet per second. The equation $h(t) = -16t^2 + 40t + 200$ represents the height of the ball h after t seconds. Write and solve the equation you would use to determine when the ball would hit the ground.

$-16t^2 + 40t + 200 = 0$
 $2t^2 - 5t - 25 = 0$
 $(2t + 5)(t - 5) = 0$
 $t = -\frac{5}{2}$, $t = 5$ seconds
~~extraneous~~

Unit 5 Review Materials

9. A water balloon is catapulted into the air. The height h of the balloon in meters is represented by the equation $h(t) = -4.9t^2 + 27t + 2.4$ where t represents the time in seconds. Write and solve the equation you would use to determine when the balloon would hit the ground.

$$-4.9t^2 + 27t + 2.4 = 0 \quad x = \frac{27 \pm \sqrt{(-27)^2 - 4(4.9)(-2.4)}}{2(4.9)}$$

$$4.9t^2 - 27t - 2.4 = 0 \quad x = \frac{27 \pm \sqrt{776.04}}{9.8} = \boxed{5.60 \text{ seconds}}$$

$a = 4.9, b = -27, c = -2.4$ or -0.9

10. Use the graph to determine if the discriminant is positive, negative, or zero. State the type of solutions the parabola has and how many solutions there are.

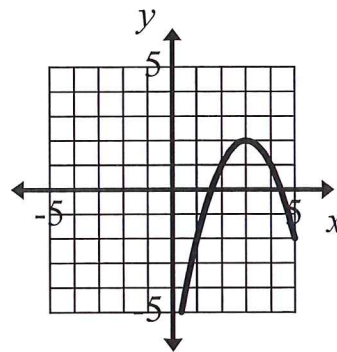
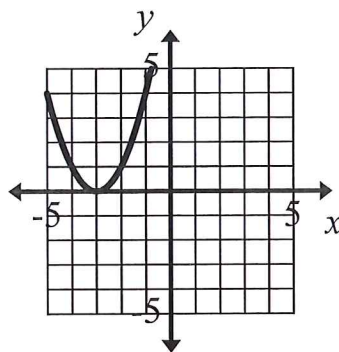
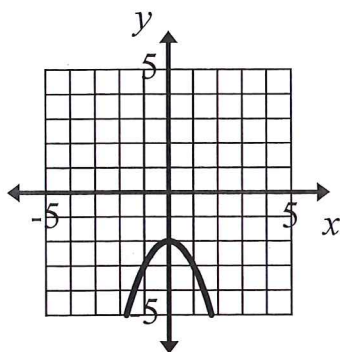

Pos/Neg/Zero: Neg Pos/Neg/Zero: Zero Pos/Neg/Zero: Pos
 # of Solutions: 2 # of Solutions: 1 # of Solutions: 2
 Type of solutions: Imaginary Type of solutions: Real, Rational Type of solutions: Real

11. Determine the discriminant of each quadratic function. State how many solutions the equation will have and what type of solutions they will be.

a) $a(x) = x^2 + 2x + 5$
 * let $d = \text{discriminant}$
 $d = b^2 - 4ac$
 $d = (2)^2 - 4(1)(5)$
 $d = 4 - 20$
 $d = -16$

b) $b(x) = 5x^2 - x - 13$
 $a = 5, b = -1, c = -13$
 $d = (-1)^2 - 4(5)(-13)$
 $= 1 + 260$
 $d = 261$

c) $c(x) = 4x^2 - 4x + 1$
 $a = 4, b = -4, c = 1$
 $d = (-4)^2 - 4(4)(1)$
 $= 16 - 16$
 $= 0$

Discriminant: -16 Discriminant: 261 Discriminant: 0
 # of Solutions: 2 # of Solutions: 2 # of Solutions: 1
 Type of solutions: Imaginary Type of solutions: Real, Irrational Type of solutions: Real, Rational

Unit 5 Review Materials

12. Which is the correct graph of $y > x^2 + 6x + 5$?

$0 = (x+1)(x+5)$
 x intercepts are -1 and -5
 line is dashed
 (b)

a)

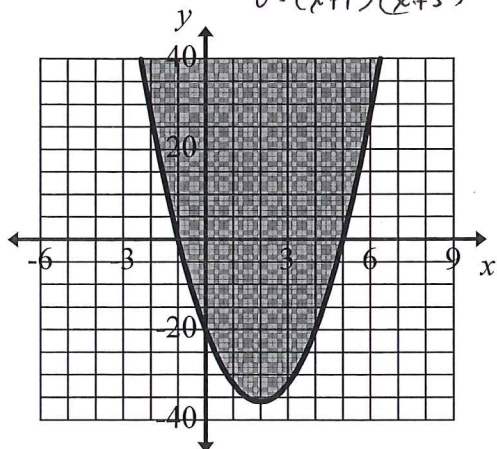

b)

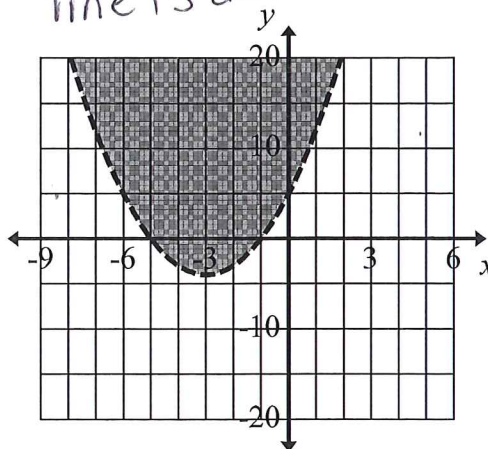

c)

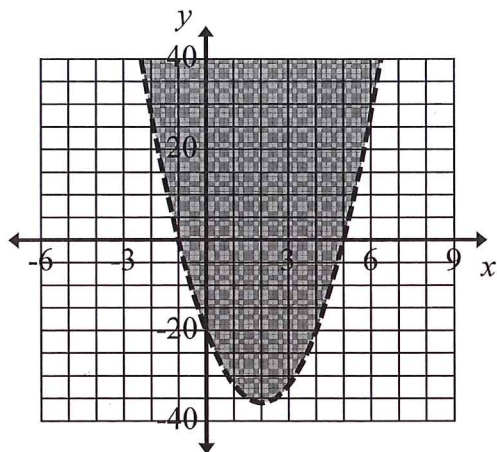

d)

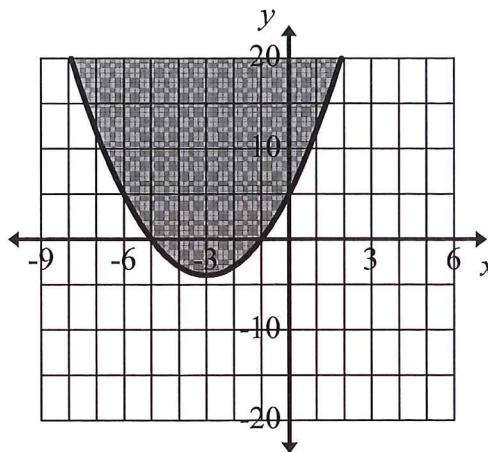

13. Use the graph above to write the solution to the inequality: $x^2 + 6x + 5 < 0$.

$-5 < x < -1$

14. List below the 4 steps that you should follow to solve a quadratic inequality.

- Algebraically find the x-intercepts
- sketch the graph of a parabola that has those x-intercepts and opens up if $a > 0$ or down if $a < 0$. Also determine dashed or solid line.
- Identify the x values for which the graph lies below the x-axis (#15a) or above (or on) the x-axis (#15b).
- For \leq or \geq , include the x-intercepts in the solution.

15. Solve each inequality by completing the 4 steps stated above.

a) $x^2 + x - 2 < 0$
 $(x+2)(x-1) = 0$
 $x = -2$ $x = 1$

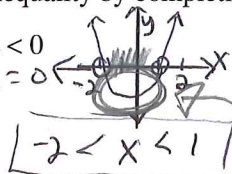

function value less than 0.

b) $x^2 + 12x \geq -32$
 $x^2 + 12x + 32 \geq 0$
 $(x+8)(x+4) = 0$
 $x = -8$ or $x = -4$

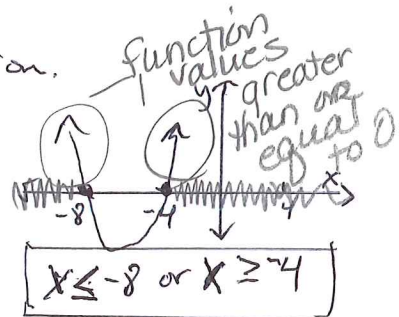

Unit 5 Review Materials

16. Which is the correct graph of $y \leq (x-4)(x+1)$? Graph b

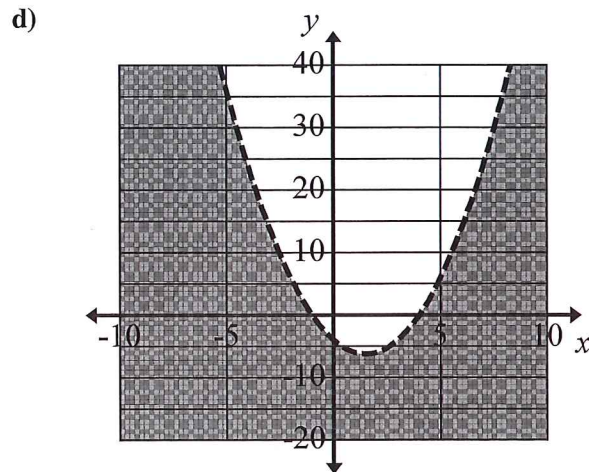
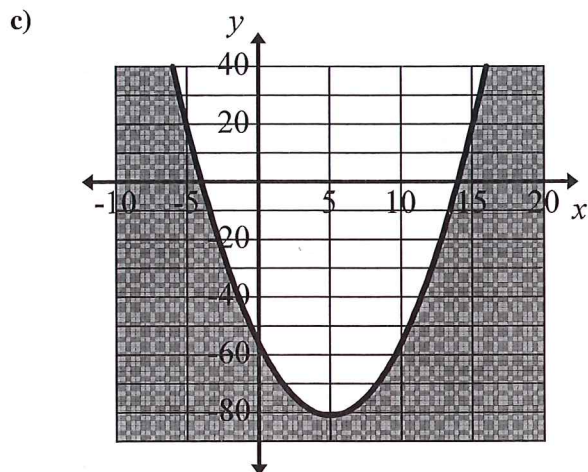
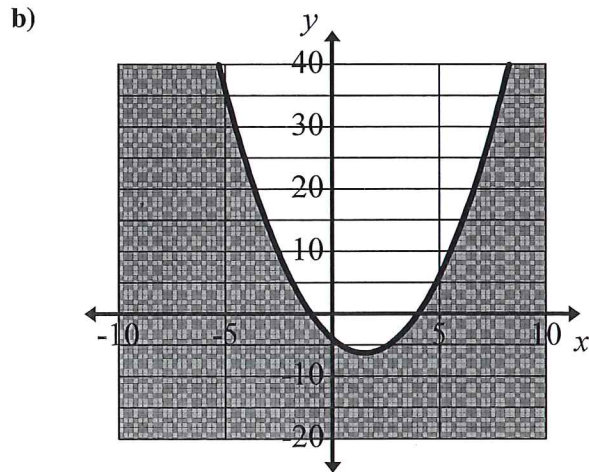
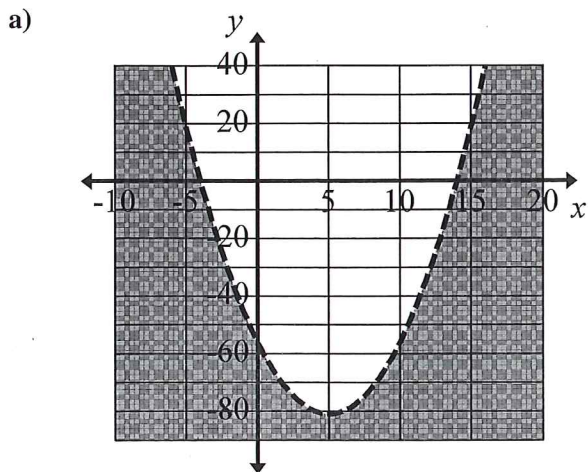

17. Use the graph above to write the solution to the inequality: $(x-4)(x+1) \geq 0$.

$$x \leq -1 \text{ or } x \geq 4$$

Unit 5 Review

Unit 5 *Review Materials*

This page intentionally left blank